

DIGITAL CLOCK DISTRIBUTOR

521 CE MARK COMPLIANT

INSTALLATION

CONTENTS	PAGE	Figures (Contd)	Page
1. GENERAL	2	3. PWR ALM (JP1) Terminal	6
2. SHELF INSTALLATION	3	4. Reference and PSM/C Input Module Switches	7
A. Required Tools and Materials	3	5. Common Equipment Panel	7
B. Unpacking	3	6. TOAA/C 2-Port BNC Interface Module .	16
C. Site Preparation	4	7. 990-45105-11 Module Jumpers	16
D. Shelf and Interface Panel Mounting	6	8. Ground and Power Connections	18
E. Shelf Switch Settings	6	9. Remote System and Shelf Connections .	21
F. CEP Module Installation	7	10. Bridging Isolator	22
G. Interface Module Installation	8	11. Wire-Wrap Reference Input Module ...	24
H. Ground Connections	17	12. Coaxial Reference Input Module	24
I. Power Connections	18	13. DCD-LPR/C Connections to DCD-521/C CEP	25
3. PRE-TEST CONNECTIONS	19	14. Data Communications Connection	26
A. Master to Expansion Shelf Interconnection	19	15. Isolated Loop Closure Inside Building (SS Type 1)	30
B. Master System to Remote System Interconnection	20	16. Isolated Closure to Ground (SS Type 2) .	30
C. Bridging Isolator Installation	22	17. Closure to Ground with Load (SS Type 3)	30
D. Reference Input Connections	23	18. Series Connections for NC Alarms Cable	32
E. DCD-LPR/C Connections	25	19. Alarm Cable Connections	32
F. Communication Port Connections .	25	20. 990-45105-06 Output Module	35
4. TEST AND ACCEPTANCE	26	21. 990-45105-10 Output Module	35
5. POST-TEST CONNECTIONS	26	22. 990-45105-11 Output Module	36
A. MIS/C ^{V5} Card in Remote System....	26	23. 990-45105-12 Output Module	36
B. Alarm, Status, and Control Terminations	26	24. 990-45105-13, -14, -15 Output Module .	37
C. Timing Output Connections	34	25. 990-45105-16, -17, -18 Output Module .	37
D. PSM/C Module Connections	40	26. 990-45108-01 Output Module	38
E. ESCIU/C Connections	41	27. 990-45108-01 Output Module for TOLA/C Card with RS-422 and RS-232 Signals ..	38
F. ESCIU/C Cutover Procedures	42	28. 990-45108-01 Output Module for TOLA/C Card with RS-423 Signals	39
Figures		29. 990-45122-01 Output Module	39
1. DCD-521/C System Configuration	5	30. Wire-Wrap PSM/C Input Module	40
2. Mounting Ear Positions (Top View)	6	31. Coaxial PSM/C Input Module	40
		32. ESCIU/C Module Connections	41
		33. ESCIU/C Cutover without Jacks (Out-of-Service)	43
		34. ESCIU/C Cutover with Jacks (In-Service)	45

Tables	Page
A. Timing Output Slot Connections in Interface Panel	8
B. Clock Input Modules for ITU-Class MMPs	9
C. PSM Modules for ITU-Class MMPs	10
D. Timing Output Modules for ITU-Class MMPs	11
E. Master to Expansion Shelf Cable Connections	20
F. DB9 COMM Connector Pin Assignments	25
G. 50-pin J5 ALARM/STATUS Pin Assignments	27
H. 50-pin J6 ALARM Pin Assignments	29
I. OS Alarm and Status Messages (Suggested)	33
J. Timing Output Card Connections	34
K. ESCIU/C Module to Access Jack Connections	41
L. ESCIU/C Module to NE Connections	42
M. ESCIU/C Alarm and Control Connections	42

1. GENERAL

1.01 This section provides installation procedures for Symmetricom’s Digital Clock Distributor 521 CE Mark Compliant (DCD-521/C) System.

1.02 This section has been reissued for the reasons listed below. Changes and additions are marked with change bars.

- Added references to MRC-EA/C^{V5} and MRC-T^{V5} cards where applicable in document.
- Added references to MIS/C^{V5} card where applicable in document.
- Updated Figure 9 and Table B.
- Changed Standard MRC-EA/C to MRC-EA/C^{V5} where applicable in document.

1.03 All product names, service marks, trademarks, and registered trademarks used in this document are the property of their respective owners.

1.04 The following abbreviations are used in this document:

ACO	alarm cutoff
BPV	bipolar violations
CAS	channel associated signaling

CC	composite clock
CCS	common channel signaling
CRC	cyclic redundancy check
DCD	Digital Clock Distributor
LOS	loss of signal
MOP	method of procedure
RU	rack unit
TNC	Transit Node Clock
TO	timing output card or slot

Notes:

1. Where information is common to the MRC-EA/C, MRC-EA/C^{V5}, MRC-T/C, MRC-T/C^{V5}, CI-EA/C, DCIM-EA/C, CI/C, and ACI/C cards, these cards are collectively referred to as clock input cards.
2. Where information is common to the MRC-EA/C, MRC-EA/C^{V5}, MRC-T/C, and MRC-T/C^{V5} cards, these cards are collectively referred to as MRC/C cards.
3. Where information is common to the PSM-E/C, PSM-T/C, and PSM-EA/C cards, these cards are collectively referred to as PSM/C cards.
4. Where information is common to the LNC/C, TNC-E/C, and TNC/C cards, these cards are collectively referred to as clock cards.
5. Reference to wire gauge size is listed in wire diameter in mils and mm with the American Wire Gauge (AWG) designation in parenthesis.
6. “Interface panel” is used when referring to either the input/output panel of the master shelf or the output panel of the expansion shelf.

1.05 The DCD-521/C System consists of a single universal shelf that can serve as either a master or an expansion shelf. For this reason, the term “expansion shelf” in this document refers to the DCD-521/C shelf used in an expansion shelf capacity, and the term “master shelf” refers to the DCD-521/C Shelf used in a master shelf capacity.

1.06 The DCD-521/C conforms to the European Standards EN55022, EN50082-1, and EN60950, and carries the CE Mark certification.

2. SHELF INSTALLATION

A. Required Tools and Materials

2.01 The following tools and materials must be on hand and provided by the customer when installing the DCD-521/C System:

- Flat-blade screwdriver (small and medium)
- Phillips screwdriver (large and medium)
- Flat-nose pliers
- Cable cutting and stripping tools
- Wire-wrap/unwrap tool
- Multimeter with high-impedance inputs and clip-type probes
- Spade/ring-terminal crimp tool for 50.8 mils, 1.29 mm (16 AWG) stranded wire size
- 25 W soldering iron (optional)
- Fine-grain sandpaper (for removing paint under ground stud)
- Conductive antioxidant (for all connections)
- Plastic tie-wrap tightening and cutting tool for miniature, intermediate, and standard size tie-wraps

B. Unpacking

2.02 This section provides guidelines and instructions for unpacking the equipment and returning damaged equipment.

Caution: *When handling cards, use local office procedures regarding electrostatic discharge (ESD), including the following:*

- Use grounded wrist straps connected to equipment frame ground when handling cards.
- Store cards only in antistatic packaging provided by the factory.

2.03 Save packing material. All equipment returned *must be packed in the original packing material. Returned equipment not packed in original packing material voids warranty.* Contact your local Symmetricom distributor, or call Symmetricom's Customer Service Department if additional packaging is needed at one of the following:

+44 1483 510300 (U.K.)

+1 408 428 7907 (U.S.A.)

Note: The following toll-free number is available in some countries to access the CTAC office in the U.S.A.:

+1 888 367 7966 (U.S.A.)

2.04 The DCD-521/C System is shipped in several boxes. One box contains the shelf assembly which consists of the (bare) card chassis, the interface panel, and the common equipment panel (CEP). Cables, mounting hardware, and this manual are also included in this box; other boxes contain the cards. Each card is packed in its own carton inside the box. Other boxes, if any, contain individual TNC-E/C clock cards.

1. Unpack equipment carefully; check for completeness against the purchase order. (Be sure to save the packing material.)
2. Notify your local Symmetricom distributor, or Symmetricom's Customer Service Department if any of the items are missing.
3. Inspect equipment for shipping damage, including bent or loose hardware, and broken connectors. Visually inspect the front and rear panels for damage; if extensive damage is found, remove the panels and inspect inside for damage.
4. Notify your local Symmetricom distributor, or Symmetricom's Customer Service Department and the carrier if equipment was damaged in transit.

C. Site Preparation

Caution: *The DCD-521/C System should not be installed near large motors, generators, transformers, or other equipment which radiates strong magnetic fields. Placing the DCD-521/C near such equipment may result in improper operation.*

2.05 The DCD-521/C may be installed in either an EIA (485 mm [19 inch]) standard rack with either 44 mm or 70 mm rack unit (RU) mounting screw holes, or an ETSI (535 mm [21 inch]) standard rack with 25 mm rack unit (RU) mounting screw holes.

2.06 This section assumes that a site survey was performed and Installation Job Specifications were developed by the local company as supplements to this section. The Installation Job Specifications should contain the following:

- The number of shelf assemblies to be installed
- The racks and rack positions where the shelf assemblies are to be installed
- Power and frame ground connections between the office and the shelves
- Cable routing lists for power, ground, inputs, and outputs

- Options for cards and placement of cards
- Assignment of timing outputs to Network Elements (NE)
- Timing lines to be monitored, if any

2.07 A DCD-521/C System consists of a master shelf and up to three expansion shelves. Each shelf assembly (master and expansion) contains a card chassis, a CEP, and an interface panel. The DCD-521/C Shelf assemblies are mounted as shown in Figure 1.

2.08 The master shelf assembly is mounted at the top of the rack or, if used in conjunction with an external reference source (i.e., a DCD-LPR/C), directly below the external reference source; expansion shelf assemblies are mounted below the master shelf assembly.

2.09 If two racks are required, the racks must be mounted adjacent and as close as possible to keep the cable length as short as possible. Refer to local company documents for ribbon cable routes between equipment racks, if permitted.

2.10 A complete DCD-521/C System in another part of the building can be slaved to the master system, allowing outputs to be located closer to NEs that require synchronization.

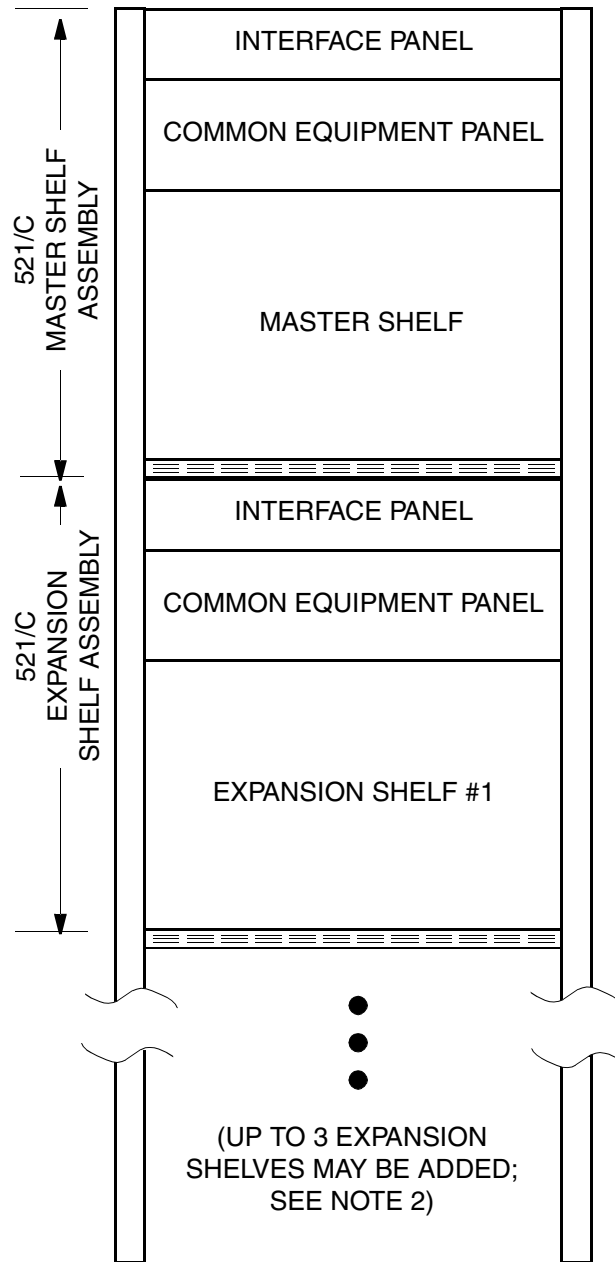

Notes:

1. The interface panels and common equipment panels for each shelf are located behind a front panel.
2. If three expansion shelves are added, a second rack may be required.
3. An optional DCD-LPR/C Shelf is typically mounted at the top of the rack.

Figure 1. DCD-521/C System Configuration

D. Shelf and Interface Panel Mounting

2.11 Mount a DCD-LPR/C at the top of the rack. If a DCD-LPR/C is not part of the installation, mount the master shelf assembly at the top of the rack.

2.12 The mounting ears on the master and expansion shelf assemblies can be positioned for either EIA (485 mm [19 inch]) or ETSI (535 mm [21 inch]) standard mounting. The shelf assemblies are shipped with the ears positioned for EIA mounting. Perform mounting as specified in the local company's Installation Job Specification as follows:

1. If the position of the mounting ears is appropriate, skip this step. Remove and attach the mounting ears on the master and expansion shelf assemblies as appropriate (Figure 2).

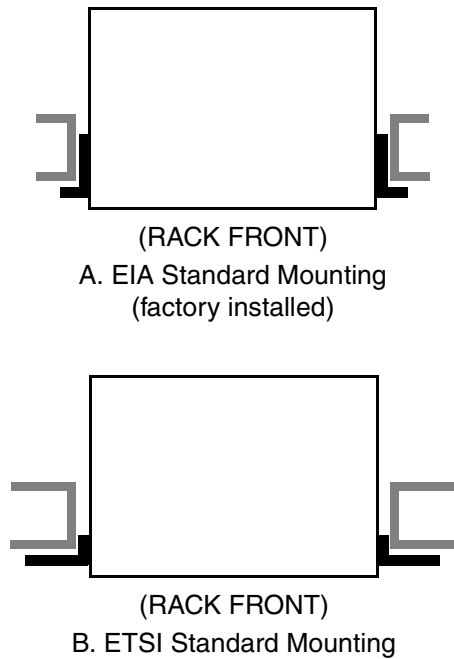

Figure 2. Mounting Ear Positions (Top View)

2. Align the mounting holes so that at least four screws on each side can be installed, and attach using the provided screws.
3. Mount the first expansion shelf directly under the master shelf. Air circulation is provided by the grill on the bottom of the shelf.

4. If capacity requires more expansion shelves, install the appropriate number of expansion shelves per instructions in Step 3.
5. If the cable distance between the DCD-521/C System and the NEs being timed exceeds the specifications, set up a slaved remote system with the appropriate number of output slots. See Part 2B, Master System to Remote System Interconnection.

E. Shelf Switch Settings

2.13 A switch and jumper terminals on the rear panel of the shelf determine shelf operations. The switches and jumpers for each shelf in a DCD-521/C System must be set to the same positions unless noted otherwise.

2.14 The TNCE/TNC switch (SW1) on the CEP (Figure 5) selects the clock operation for the shelf.

- a. The TNCE position sets the master shelf for operation with rubidium (TNC-E/C) clock cards, and 090-44010-08, -09, -57, and -57T MRC/C cards. The expansion shelf must be set to the factory setting (TNC).
- b. The TNC position sets the master shelf for operation with quartz (TNC/C or LNC/C) clock cards, unless a TNCE/C card is also installed. This switch must be set to the factory setting (TNC) on the expansion shelves.

2.15 The PWR ALM (JP1) terminal (Figure 3) on the CEP determines the alarm issued when all power is lost to the shelf. Without straps, the shelf issues a major and a minor alarm. With a strap between the center pin and the MAJ pin, the shelf issues a major alarm. With a strap between the center pin and the MIN pin, the shelf issues a minor alarm.

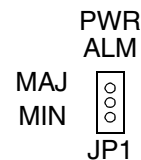

Figure 3. PWR ALM (JP1) Terminal

F. CEP Input Module Installation

2.16 The REF INPUTS A and REF INPUTS B connectors on the CEP (Figure 5) are for references input modules. These modules carry reference input signals for the clock input cards in the MR A and MR B slots. The MON1 and MON2 connectors are used for the PSM/C modules. These modules carry signals for PSM/C cards installed in the MON1 and MON2 slots. To install a module on the CEP:

1. Choose the appropriate module for each PSM/C card to be installed on the master shelf.

Note: Each module contains switches used to determine whether or not to tie the shield to frame ground. Tying the shield to ground is ordinarily not required, but may be used in noisy environments to reduce noise.
2. Set the module switches to OPEN to leave the cable shield open (floating). Set the module switches to FGND or OPEN as appropriate.
3. To install a module, line up the three spring-loaded screws to the holes on the panel.
4. Use a medium flat-blade screwdriver to lock each screw in place. Screw in evenly to prevent

skewing the module. Also make sure that the top screw is securely in place; this is the FRM GND connection to the CEP.

5. Repeat Steps 1 through 4 for each module in each shelf in each local and remote system, if applicable.

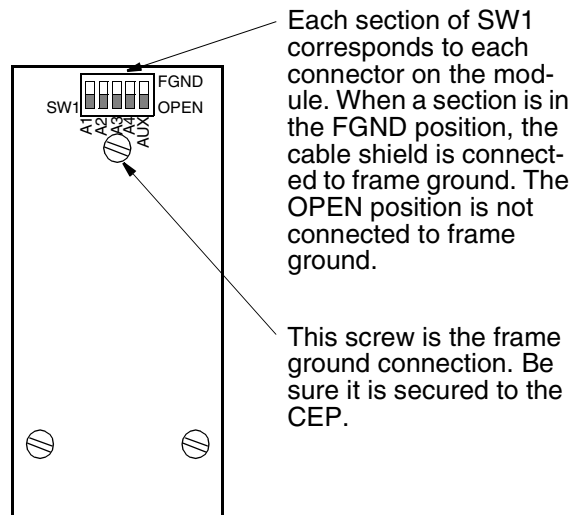

Figure 4. Reference and PSM/C Input Module Switches

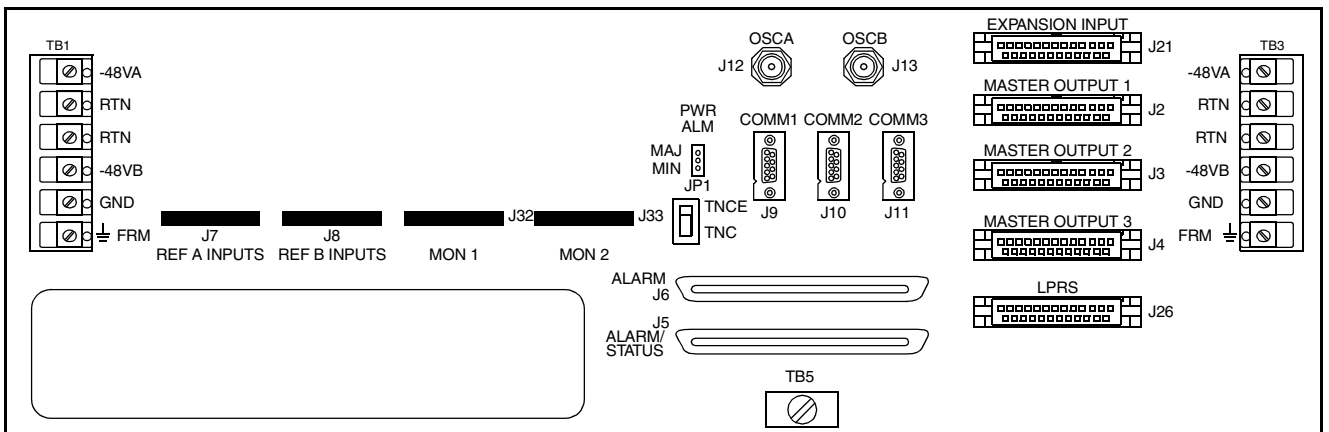

Figure 5. Common Equipment Panel

G. Interface Module Installation

2.17 The interface panel is located above the CEP and contains connectors for the timing output modules and the PSM/C input modules.

2.18 Install an interface module in the position corresponding to the slot the card is to be installed (Table A). Installation procedures for the master and expansion shelves are identical.

2.19 To install the interface modules:

1. Choose the appropriate interface module for each output card to be installed (refer to Tables B through D) on the shelf.

- 2-port BNC interface module (Figure 6): install the appropriate attenuation pads (2 dB, 3 dB, 3.5 dB, 6 dB, 30 dB, or 60 dB) on the interface module. (The pad values should be determined from the local company Installation Job Specifications.) To install the pads, line up the pins on the pad with U1 (with labeling on the pad right-side up) and insert until firmly seated. Repeat for U2.

- 2-port BNC interface module (Figure 6): if required to isolate DC ground (SHIELD) from DCD equipment, remove jumper(s) (DC GND), J1 and/or J2.

- PSM/C input modules (Figure 4): The sections of SW1 determine whether the shield of the associated connector is connected to ground at the DCD Shelf. The OPEN position holds the shield disconnected from ground.

- 990-45105-11 module (Figure 7): determines which external equipment is to be connected by wire-wrap cable and which by Siemens 1.6/5.6 connections. When the jumper is connected (factory setting), the wire-wrap connectors are active. When the jumper is not connected, the coaxial connectors are active. Each port (OUT 1 through OUT10) can be set independently.

2. Align the three spring-loaded screws on the modules with the holes on the panel.
3. Use a medium flat-blade screwdriver to lock each screw in place. Torque the screws evenly to prevent skewing the module.

Caution: Make sure the top screw is securely in place; this is the frame ground connection to the interface panel.

4. Repeat Steps 1 through 3 for all modules.
5. Repeat Steps 1 through 4 for each expansion shelf in the system, if applicable.
6. Repeat Steps 1 through 5 for the remote system, if applicable.

Table A. Timing Output Slot Connections in Interface Panel

CARD SLOT	MASTER SHELF INTERFACE PANEL		EXPANSION SHELF INTERFACE PANEL
	WITH TNC-E/C	WITH TNC/C	(NO CLOCK CARDS)
TO1	(not used)	I/O 1	I/O 1
TO2	(not used)	I/O 2	I/O 2
TO3	(not used)	I/O 3	I/O 3
TO4	I/O 4	I/O 4	I/O 4
TO5	I/O 5	I/O 5	I/O 5
TO6	I/O 6	I/O 6	I/O 6
TO7	I/O 7	I/O 7	I/O 7
TO8	I/O 8	I/O 8	I/O 8

Table B. Clock Input Modules for ITU-Class MMPs

FOR INPUT CARD	USE INPUT MODULE				
	PART NUMBER	CONNECTOR TYPE	IMPEDANCE	INPUT SIGNAL LEVEL	NO. OF INPUTS
ACI/C (Connect input at AUX or A5 only)	990-45107-02	SMB	75 Ω (unbalanced)	0.3 V to 1.5 V rms (AUX only)	4 + AUX (Use AUX)
	990-45107-03	Siemens 1.6/5.6	75 Ω (unbalanced)	0.3 V to 1.5 V rms (AUX only)	4 + AUX (Use AUX)
	990-45107-04	Siemens 1.0/2.3	75 Ω (unbalanced)	0.3 V to 1.5 V rms (A5 only)	5 (Use A5)
CI/C (Connect inputs at A3 only) (TERM or BRDG) (Note 2)	990-45107-06	Wire-wrap	T1: 100 Ω (balanced) CC: 133 Ω (balanced)	TERM: T1: 1.0 V to 3.5 V b-p BRDG: T1: 0.1 V to 0.35 V b-p BRDG: CC: 1.5 V to 4.0 V p-p	4 (Use A3)
CI-EA/C (Connect input at A3, AUX, or A5 only) (TERM or BRDG) (Note 2)	990-45107-02	SMB	75 Ω (unbalanced)	TERM: E1: 1.0 V to 3.5 V b-p (A3 only) BRDG: E1: 0.1 V to 0.35 V b-p (A3 only) BRDG: Analog: 1.5 V to 3.0 V p-p (AUX only)	4 + AUX (Use inputs listed)
	990-45107-03	Siemens 1.6/5.6	75 Ω (unbalanced)	TERM: E1: 1.0 V to 3.5 V b-p (A3 only) BRDG: E1: 0.1 V to 0.35 V b-p (A3 only) BRDG: Analog: 1.5 V to 3.0 V p-p (AUX only)	4 + AUX (Use inputs listed)
	990-45107-04	Siemens 1.0/2.3	75 Ω (unbalanced)	TERM: E1: 1.0 V to 3.5 V b-p (A3 only) BRDG: E1: 0.1 V to 0.35 V b-p (A3 only) BRDG: Analog: 1.5 V to 3.0 V p-p (A5 only)	5 (Use inputs listed)
	990-45107-06	Wire-wrap	120 Ω (balanced)	TERM: E1: 1.0 V to 3.5 V b-p (A5 only) BRDG: E1: 0.1 V to 0.35 V b-p (A3 only)	4 (Use inputs listed)

Table B. Clock Input Modules for ITU-Class MMPs (Contd)

FOR INPUT CARD	USE INPUT MODULE				
	PART NUMBER	CONNECTOR TYPE	IMPEDANCE	INPUT SIGNAL LEVEL	NO. OF INPUTS
MRC-EA/C MRC-EA/C ^{v5} MRC-T/C DCIM-EA/C (Connect all inputs to A1 through A4)	990-45107-02	SMB	75 Ω (unbalanced)	E1 and analog: 0.1 V to 3.5 V b-p	4 + AUX (Do not use AUX)
	990-45107-03	Siemens 1.6/5.6	75 Ω (unbalanced)	E1 and analog: 0.1 V to 3.5 V b-p	4 + AUX (Do not use AUX)
	990-45107-04	Siemens 1.0/2.3	75 Ω (unbalanced)	E1 and analog: 0.1 V to 3.5 V b-p	5 (Do not use A5)
	990-45107-06	Wire-wrap	120 Ω (balanced)	E1 and analog: 0.1 V to 3.5 V b-p	4

Notes:

1. TERM indicates an input terminated at the module, BRDG indicates an input connected to the module via a bridging isolator.
2. Part numbers shown are for ordering purposes; part numbers on modules start with 089 instead of 990.

Table C. PSM Modules for ITU-Class MMPs

FOR INPUT CARD	USE INPUT MODULE				
	PART NUMBER	CONNECTOR TYPE	IMPEDANCE	INPUT SIGNAL LEVEL	NO. OF INPUTS
PSM-T/C	990-45106-11	Wire-wrap (Note 1)	100 Ω (balanced)	T1: 0.1 V to 3.5 V b-p	4
PSM-E/C PSM-EA/C	990-45106-11	Wire-wrap (Note 1)	120 Ω (balanced)	E1: 0.1 V to 3.5 V b-p	4
	990-45106-12	Siemens 1.6/5.6	75 Ω (unbalanced)	E1 and analog: 0.1 V to 3.5 V b-p	4
	990-45106-13	BNC	75 Ω (unbalanced)	E1 and analog: 0.1 V to 3.5 V b-p	4
	990-45106-14	SMB	75 Ω (unbalanced)	E1 and analog: 0.1 V to 3.5 V b-p	4
	990-45106-15	Siemens 1.0/2.3	75 Ω (unbalanced)	E1 and analog: 0.1 V to 3.5 V b-p	4

Notes:

1. Use this module for E1 or T1 signals only.
2. Part numbers shown are for ordering purposes; part numbers on modules start with 089 instead of 990.

Table D. Timing Output Modules for ITU-Class MMPs

FOR OUTPUT CARD	USE MODULE				
	PROTECTION TYPE	USE PART NUMBER:	CONNECTOR TYPE	IMPEDANCE	NO. OF OUTPUTS
ESCIU/C	Stand-alone	090-45021-11	SMB	75 Ω (unbalanced)	I/O for 2-way E1
		090-45021-12	Siemens 1.6/5.6	75 Ω (unbalanced)	I/O for 2-way E1
EA10/C EA10M/C	Stand-alone	990-45105-06	Wire-wrap (Note 1)	E1: 120 Ω (balanced)	10
		990-45105-13	SMB	E1: 75 Ω Analog: 75 Ω (unbalanced)	10
		990-45105-14	Siemens 1.6/5.6	E1: 75 Ω Analog: 75 Ω (unbalanced)	10
		990-45105-15	Siemens 1.0/2.3	E1: 75 Ω Analog: 75 Ω (unbalanced)	10
		990-45108-01	Wire-wrap (Note 1)	E1: 120 Ω Analog: 75 Ω (balanced)	10 (11, 12, 13 not used)
	1:1, 1+1	990-45105-10 (double-wide)	Wire-wrap (Note 1)	E1: 120 Ω (balanced)	10
		990-45105-11 (double-wide)	Wire-wrap or Siemens 1.6/5.6	E1: 120 Ω (balanced) or E1: 75 Ω Analog: 75 Ω (unbalanced)	10
		990-45105-16 (double-wide)	SMB	E1: 75 Ω Analog: 75 Ω (unbalanced)	10
		990-45105-17 (double-wide)	Siemens 1.6/5.6	E1: 75 Ω Analog: 75 Ω (unbalanced)	10
		990-45105-18 (double-wide)	Siemens 1.0/2.3	E1: 75 Ω Analog: 75 Ω (unbalanced)	10
		TOAA/C (except 090-44028-10)	Stand-alone	990-45122-01	BNC

Table D. Timing Output Modules for ITU-Class MMPs (Contd)

FOR OUTPUT CARD	USE MODULE				
	PROTECTION TYPE	USE PART NUMBER:	CONNECTOR TYPE	IMPEDANCE	NO. OF OUTPUTS
TOAA/C (090-44022-02)	Stand-alone	990-45122-01	BNC	Analog: 50 Ω (unbalanced) (includes 0 dB, 3.0 dB, 3.5 dB, 30.0 dB, 60.0 dB pads)	2
TOCA/C	Stand-alone	990-45108-01	Wire-wrap (Note 1)	CC: 133 Ω (balanced)	10 (Do not use 11, 12, 13)

Table D. Timing Output Modules for ITU-Class MMPs (Contd)

FOR OUTPUT CARD	USE MODULE				
	PROTECTION TYPE	USE PART NUMBER:	CONNECTOR TYPE	IMPEDANCE	NO. OF OUTPUTS
TO-EA5/C	Stand-alone	990-45105-06	Wire-wrap (Note 1)	E1: 120 Ω (balanced)	10
		990-45105-12	Wire-wrap and Siemens 1.6/5.6	E1: 120 Ω (balanced) and E1: 75 Ω Analog: 75 Ω (unbalanced)	5 Wire-wrap and 5 Siemens 1.6/5.6
		990-45105-13	SMB	E1: 75 Ω Analog: 75 Ω (unbalanced)	10
		990-45105-14	Siemens 1.6/5.6	E1: 75 Ω Analog: 75 Ω (unbalanced)	10
		990-45105-15	Siemens 1.0/2.3	E1: 75 Ω Analog: 75 Ω (unbalanced)	10
		990-45108-01	Wire-wrap (Note 1)	E1: 120 Ω Analog: 75 Ω (balanced)	10 (Do not use 11, 12, 13)
	1:1, 1+1	990-45105-10 (double-wide)	Wire-wrap (Note 1)	E1: 120 Ω (balanced)	10
		990-45105-11 (double-wide)	Wire-wrap or Siemens 1.6/5.6	E1: 120 Ω (balanced) or E1: 75 Ω Analog: 75 Ω (unbalanced)	10 Wire-wrap or 10 Siemens 1.6/5.6 or combination
		990-45105-16 (double-wide)	SMB	E1: 75 Ω Analog: 75 Ω (unbalanced)	10
		990-45105-17 (double-wide)	Siemens 1.6/5.6	E1: 75 Ω Analog: 75 Ω (unbalanced)	10
		990-45105-18 (double-wide)	Siemens 1.0/2.3	E1: 75 Ω Analog: 75 Ω (unbalanced)	10

Table D. Timing Output Modules for ITU-Class MMPs (Contd)

FOR OUTPUT CARD	USE MODULE					
	PROTECTION TYPE	USE PART NUMBER:	CONNECTOR TYPE	IMPEDANCE	NO. OF OUTPUTS	
TO-EA/C	Stand-alone	990-45105-12	Wire-wrap and Siemens 1.6/5.6	E1: 120 Ω Analog: 75 Ω (balanced) and E1: 75 Ω Analog: 75 Ω (unbalanced)	5 Wire-wrap and 5 Siemens 1.6/5.6	
		990-45105-13	SMB	E1: 75 Ω Analog: 75 Ω (unbalanced)	10	
		990-45105-14	Siemens 1.6/5.6	E1: 75 Ω Analog: 75 Ω (unbalanced)	10	
		990-45105-15	Siemens 1.0/2.3	E1: 75 Ω Analog: 75 Ω (unbalanced)	10	
		990-45108-01	Wire-wrap (Note 1)	E1: 120 Ω (balanced)	10 (Do not use 11, 12, 13)	
	1:1, 1+1	990-45105-10 (double-wide)	Wire-wrap (Note 1)	E1: 120 Ω (balanced)	10	
		990-45105-11 (double-wide)	Wire-wrap or Siemens 1.6/5.6	E1: 120 Ω (balanced) or E1: 75 Ω Analog: 75 Ω (unbalanced)	10 Wire-wrap or 10 Siemens 1.6/5.6 or combination	
	TOEA/C	Stand-alone	990-45105-12	Wire-wrap and Siemens 1.6/5.6	E1: 120 Ω (balanced) or E1: 75 Ω (unbalanced)	5 Wire-wrap and 5 Siemens 1.6/5.6
			990-45105-13	SMB	E1: 75 Ω (unbalanced)	10
			990-45105-14	Siemens 1.6/5.6	E1: 75 Ω (unbalanced)	10
990-45105-15			Siemens 1.0/2.3	E1: 75 Ω (unbalanced)	10	
990-45108-01			Wire-wrap (Note 1)	E1: 120 Ω (balanced)	10 (Do not use 11, 12, 13)	

Table D. Timing Output Modules for ITU-Class MMPs (Contd)

FOR OUTPUT CARD	USE MODULE				
	PROTECTION TYPE	USE PART NUMBER:	CONNECTOR TYPE	IMPEDANCE	NO. OF OUTPUTS
TOGA/C	Stand-alone	990-45105-12	Wire-wrap and Siemens 1.6/5.6	Analog: 75 Ω (unbalanced)	5 Wire-wrap and 5 Siemens 1.6/5.6
		990-45105-13	SMB	Analog: 75 Ω (unbalanced)	10
		990-45105-14	Siemens 1.6/5.6	Analog: 75 Ω (unbalanced)	10
		990-45105-15	Siemens 1.0/2.3	Analog: 75 Ω (unbalanced)	10
	1+1	990-45105-16 (double-wide)	SMB	Analog: 75 Ω (unbalanced)	10
TOLA/C	Stand-alone	990-45108-01	Wire-wrap (Note 1)	RS-422: 100 Ω (balanced) RS-423 (TTL): 450 Ω (unbalanced)	10 (Do not use 11, 12, 13)
TOTA/C	Stand-alone	990-45105-06	Wire-wrap (Note 1)	T1: 100 Ω (balanced)	10
		990-45108-01	Wire-wrap (Note 1)	T1: 100 Ω (balanced)	10 (Do not use 11, 12, 13)

Notes:

1. Use this module for E1 or T1 signals only.
2. Part numbers shown are for ordering purposes; part numbers on modules start with 089 instead of 990.

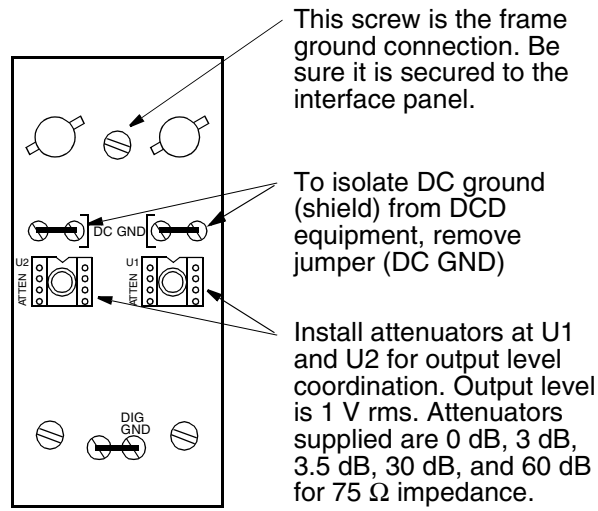

Figure 6. TOAA/C 2-Port BNC Interface Module

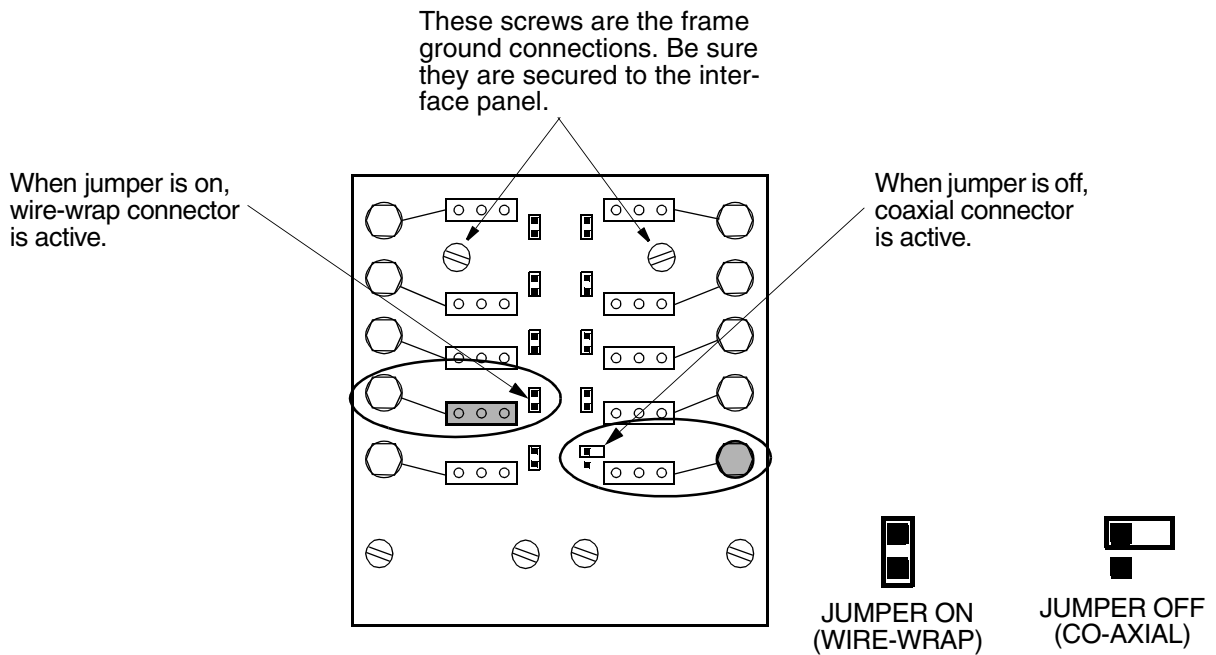

Figure 7. 990-45105-11 Module Jumpers

H. Ground Connections

2.20 Grounding connections are made from the TB1 FRM terminal, the TB3 FRM terminal, and the TB5 terminal on the CEP to frame ground. Figure 5 shows the locations of the terminal blocks on the CEP. Frame ground is a #6 ground rod connected to the rack, or the rack itself.

Note: Connect one or both of the GND (digital ground) terminals on the master shelf CEP to an office digital signal ground or signal return path, if available. If expansion shelves are used, connect each of the expansion shelf frame ground terminals to each other and to the master shelf frame ground terminal.

Note: Use 50.8 mils, 1.29 mm (16 AWG) stranded wire with green insulation for grounding connections; these wires are to be supplied by the user.

Note: Ensure the ground source is properly installed.

1. Remove the front panel of the master shelf or expansion shelf to expose the interface panel and CEP.
2. Using a small flat-blade screwdriver, slightly unscrew the set screw on TB1 FRM or TB3 FRM on the master shelf CEP. Strip 5 mm of insulation from one end of the 50.8 mils, 1.29 mm (16 AWG) wire, and insert in the hole behind the set screw. Tighten the set screw.

2.21 Use one of the two methods following to connect the other end of that wire to frame ground.

Using a #6 Ground Rod as Frame Ground

Note: Use a 25 W soldering iron to heat sufficiently the #6 rod.

1. Strip enough insulation from the wire to allow three complete turns around the #6 rod.
2. Crimp an appropriate size spade lug to the ground wire, bend the lug around the #6 rod, and solder the lug.
3. Turn the wire around the rod and solder the wire to the rod.
4. Strip approximately 5 mm of insulation from the other end of the wire, and crimp a spade lug or ring-terminal lug to the wire.
5. Screw the lug to FRM on the terminal block.
6. Repeat Steps 1 to 5 for each shelf and interface panel in the system that uses a #6 ground rod as a frame ground.
7. Repeat Steps 1 to 6 for remote systems if applicable.

Using a Rack as Frame Ground

1. Find an unused screw hole on the rack and sand the paint from around the hole to ensure good contact.
2. Prepare the 50.8 mils, 1.29 mm (16 AWG) gauge wire and crimp a spade lug to it. Screw the lug to the rack.
3. Strip approximately 5 mm of insulation from the other end of the wire, and crimp a spade lug or ring-terminal lug to the wire.
4. Screw the lug to FRM on the terminal block.
5. Repeat Steps 1 to 4 for each shelf and interface panel in the system that uses a rack as a frame ground.
6. Repeat Steps 1 to 5 for remote systems if applicable.

I. Power Connections

2.22 TB1 and TB3 on the CEP (Figure 5) are screw-down compression type office battery connections; either can be used. Both terminal blocks contain terminals for all batteries, returns, and grounds. Figure 8 illustrates the power connections.

2.23 The fuses for the DCD-521/C master and expansion shelves are rated at 5 A. Fuses at the fuse bay should be 150% of the shelf rating, or the nearest larger size (8 A).

Note: Ensure that the A and B power loads are from separate sources and cable routes are as diverse as possible. Do not route redundant leads parallel to each other in the same cable rack. Leads A and B must be

routed down separate sides of each shelf. If the site only has one power source, route both A and B feeds from that single source, and route the cables in diverse paths.

Note: Use two 50.8 mils, 1.29 mm (16 AWG) stranded wires for power connections, one with red insulation (-48V) and the other with black insulation (RTN); these wires are not provided and must be supplied by the user.

2.24 Use 50.8 mils, 1.29 mm (16 AWG) stranded wire to connect office battery supply leads from the external power source to the terminals on the DCD-521/C CEP. The -48 V dc A and B input voltage supplies can be either filtered or unfiltered.

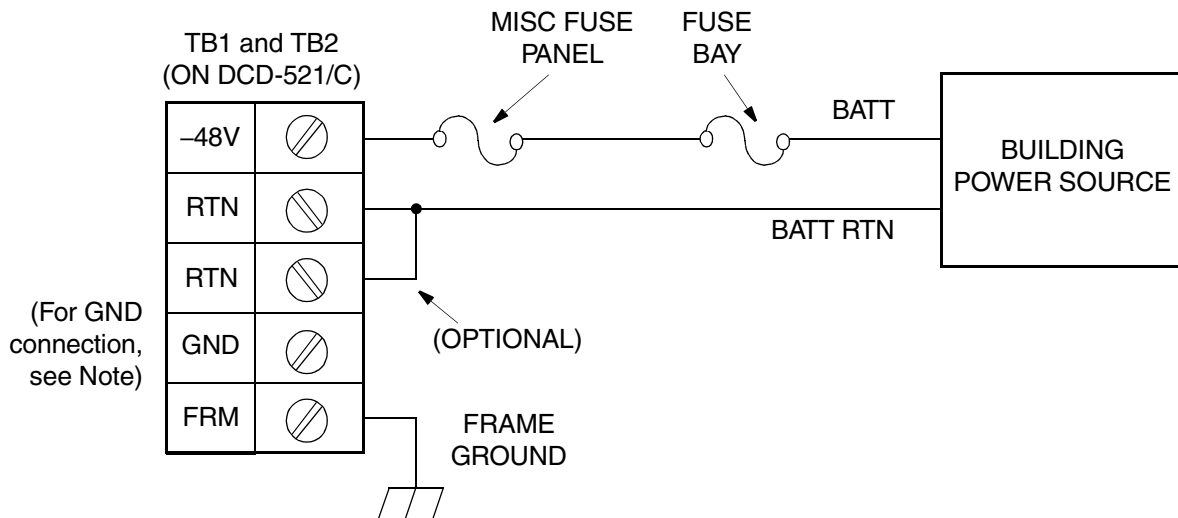

Note: To prevent battery return to frame ground fault, do not connect digital GND or battery RTN to FRM ground on either the master or the expansion shelves, or on any shelf in a remote system.

Figure 8. Ground and Power Connections

2.25 The greatest diversity in cable routes is highly recommended. The power sources should be specified in the local company Installation Job Specifications. The sources may be from a battery distribution fuse board (BDFB), a miscellaneous fuse bay, or a miscellaneous fuse panel in the same rack as the DCD-521/C. Several options for power cable routes are available. Either power lead may be connected to either terminal block.

Note: Be sure the -48 V dc source is electrically isolated from the ac source and reliably connected to earth ground.

Note: Two RTN terminals exist as a grounding option on the DCD-521/C. The user may select whether or not to double the battery return wiring. Use 50.8 mils, 129 mm (16 AWG) stranded wire to connect RTN leads from the fuse panel to the terminals on the DCD-521/C CEP.

Procedure for Connecting Power

1. Remove shelf fuses from the front panel.
2. Remove battery source fuses from the rack fuse bay.
3. Route the power wires from the power source(s) to the DCD-521/C Shelf.
4. Crimp spade or ring-terminal lugs (provided by user) to the shelf end of the power and return wires.
5. Connect A power source lugs to -48V A and RTN terminals on TB3.
6. Connect B power source lugs to -48V B and RTN terminals on TB1.
7. Verify with a volt-ohmmeter that there are no foreign battery, grounds, or shorts at the power source end of the wires.

8. Connect the leads to the power source terminals with the appropriate type of connectors or lugs.

Note: If power sources are directly from the BDFB, develop a separate, detailed Method of Procedure (MOP) to cut leads into the BDFB.

9. Reinstall shelf fuses in the front panel and repeat Step 1 through Step 8 for each shelf in the system (master and remote, if applicable).
10. Using a multimeter, verify that the input voltage level is between -42 V dc and -56 V dc at the following terminals:
 - -48V B and RTN terminals of TB1 (if used)
 - -48V A and RTN terminals of TB2 (if used)
11. Reinstall shelf fuses in the front panel and repeat Step 1 through Step 10 for each shelf in the system (master and expansion shelves in both master and remote systems, if applicable).

3. PRE-TEST CONNECTIONS

A. Master to Expansion Shelf Interconnection

Note: If a remote system will be attached to the master system, do not connect the expansion shelves at this point. Proceed to Part 3B.

3.01 Refer to Figure 5 and Figure 9 to connect the master shelf assembly CEP to the CEP on each expansion shelf assembly as follows:

1. Connect the provided 25-pin cable (p/n 060-44210-04) between the connectors of the shelves per Figure 5 and Figure 9.

Note: Cabling shown in Figure 9 is for reference only, and should not be considered as the recommended cable placement. Cables should be run as short and straight as possible.

2. Route expansion cables to the right or left, out through the cable access slot. If required, secure cables to the cable bar using tie wraps.

B. Master System to Remote System Interconnection

3.02 Master and expansion shelf outputs from one DCD-521/C System can be used as inputs to remote systems within the building. A remote system consists of a master shelf and expansion shelves, mounted and connected as the master DCD-521/C System. Figure 9 shows the recommended standard configuration for remote systems.

3.03 The systems can be connected by a 25.3 mils, 0.643 mm (22 AWG) tinned solid copper, shielded twisted pair cable.

Note: The maximum cable distance is given for each card in the Description and Specifications section of this manual.

3.04 Refer to Figure 9 to connect a master system to a remote system. The master and remote systems can be equipped for phase-aligned timing signals or G.703 timing signals.

Phase-aligned Master/Remote Systems

3.05 If phase-aligned timing signals (64 kb/s messaging using CC signals) are required by the switching office, equip the systems as follows:

- Master system: requires two TOCA/C cards, one in any slot of the master shelf and the other in

any slot of the expansion shelf. If no expansion shelf is installed, both TOCA/C cards may be installed in the master shelf.

- Remote system: master shelf requires two CI/C cards set for CC inputs. One or two clock cards provide holdover during any timing interruptions.

G.703 Master/Remote Systems

3.06 If 2.048 Mb/s (G.703), 2.048 MHz (G.703), or 1.544 Mb/s signals are used, phase alignment is not required. Equip the system as follows:

- Master system: use one output from a EA10/C, EA10M/C, TOGA/C, TO-EA5/C, TO-EA/C, or TOEA/C card in one shelf, and another output from another card of the same type in a different shelf.
- Remote system: master shelf requires ACI/C cards for TOGA/C outputs, or CI-EA/C cards for the other outputs from the master system. One or two clock cards provide holdover during any timing interruptions.

Note: If other frequencies supported by the DCD are used, consult the switching or transmission elements guide to determine if phase alignment is critical.

Table E. Master to Expansion Shelf Cable Connections

FROM MASTER SHELF		TO EXPANSION SHELVES	
MASTER OUTPUT 1	J2	EXPANSION SHELF 1: EXPANSION INPUT	J21
MASTER OUTPUT 2	J3	EXPANSION SHELF 2: EXPANSION INPUT	J21
MASTER OUTPUT 3	J4	EXPANSION SHELF 3: EXPANSION INPUT	J21

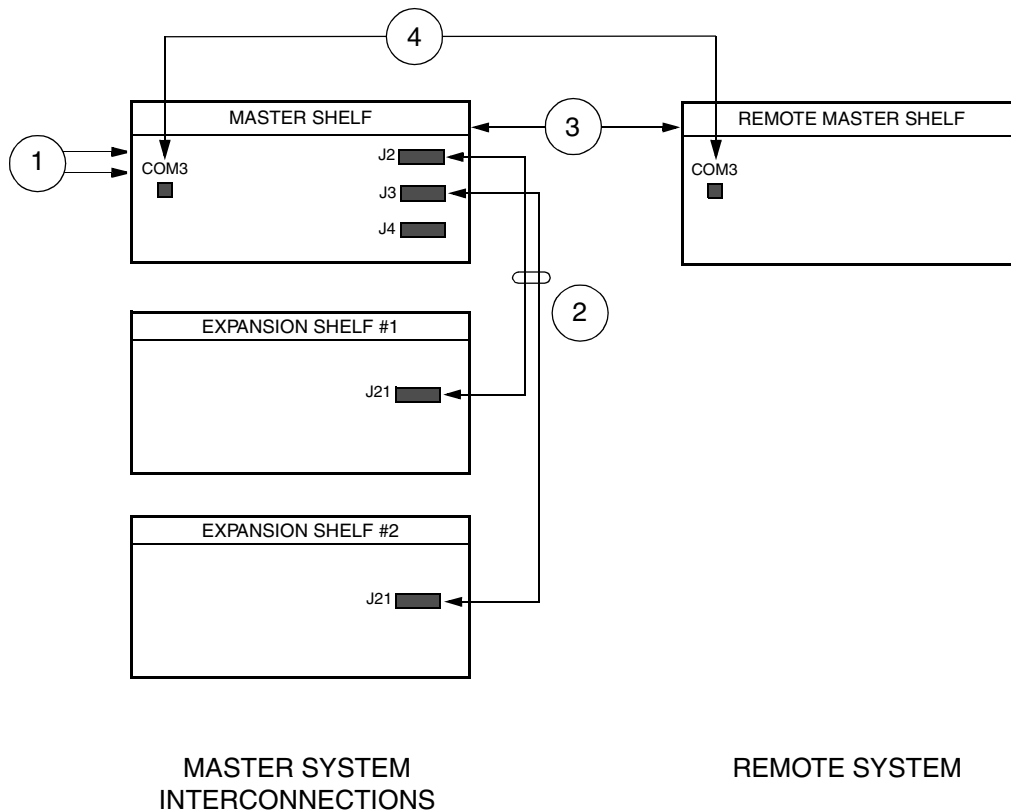

- ① Upstream reference
- ② Expansion ribbon cables: Make connections from MASTER OUTPUT 1 and 2 on the master shelf to “EXPANSION INPUT” on the corresponding expansion shelf with the provided cable (p/n 060-44210-02). If the MIS/C^{V5} card is used, do not connect before MIS/C^{V5} card is installed.
- ③ For phase-aligned systems, connect from two TOCA/C card outputs on the master system to two CI/C cards on the remote system. For G.703 systems, connect two TOEA/C, TO-EA5/C, or TO-EA/C, card outputs from the master system to CI-EA/C cards on the remote system, or two TOGA/C outputs from the master system to ACI/C cards on the remote system. The cables must be diversely routed. Use 25.3 mils, 0.643 mm (22 AWG), tinned solid copper, shielded twisted pair cable.
- ④ RS-232 communications between MIS cards in master shelves (COM3 of master system connects to COM3 of remote system). If the MIS/C^{V5} card is used, do not connect before MIS/C^{V5} card is installed.

Notes:

- 1. The remote system master shelf can be equipped with one or two LNC/C clock cards to provide holdover timing if both timing inputs fail.
- 2. Cabling is shown to illustrate connections only. Follow local company practice for cable runs.
- 3. If communications are not required, up to 3 expansion shelves may be used on both the master system and remote system.

Figure 9. Remote System and Shelf Connections

Connecting the Systems

3.07 Refer to Figures 5 and 9 to connect the master system to the remote system as follows:

Note: If the installation uses an MIS/C^{V5} in the remote system, the MIS/C^{V5} is installed in the Test and Acceptance procedures. Do not connect RS-232 cable and expansion shelves at this time.

1. Set up and mount a DCD-521/C System in the same manner as a master system (Parts 2A through 3A) at a remote site in the building.

Note: The shield (S) terminals on TB12 and TB13 are connected to frame ground inside the shelf. If the input reference cable shield leads are connected to frame ground at the signal source end (e.g., at the output card in the master system), the shield lead of the cable *must not be connected* to the S terminal at TB12 and TB13, or vice versa. Do not connect the cable shield to frame ground at both ends.

2. (Phase-aligned) Use 25.3 mils, 0.643 mm (22 AWG) tinned solid copper, shielded twisted pair cable, to connect an output port from any pair of TOCA cards (can be located in different shelves) in the master system to the CCK inputs (TB12 and TB13) on the remote master shelf (see Figure 9).
2. (G.703) Connect from two outputs on the master system to reference input modules on the remote system. The cables must be diversely routed. Use 25.3 mils, 0.643 mm (22 AWG), tinned solid copper, shielded twisted pair cable.

C. Bridging Isolator Installation

3.08 The bridging isolator (Figure 10) is inserted in a cable to bridge a reference input signal or traffic-carrying E1/CEPT to the DCD Shelf. A connection from the bridging isolator may be used as a reference input for a clock input card, or as an input for a PSM/C card.

3.09 The bridging isolator provides one or three 750 Ω high impedance bridged connections which have 20.8 dB isolation from the through signal. The signal grounds are carried through the bridging isolator for both the through signal and the bridged signal.

3.10 Install the bridging isolator at any point on the cable as shown in Figure 10. The bridging isolator may be connected to the rack, located in a cable tray, or supported by the cable in a vertical cable run. A cable from the bridging output to the DCD-521/C Shelf input must be less than 100 meters.

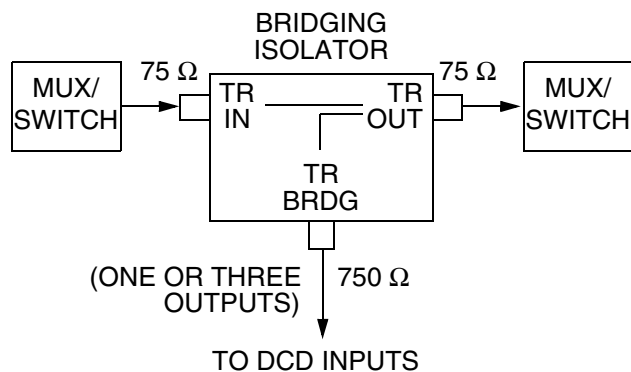

Figure 10. Bridging Isolator

D. Reference Input Connections

Installation Considerations

3.11 If the local company Installation Job Specifications do not specify the DCD Shelf timing input assignments, a local assignment plan must be developed before proceeding with the connections. Reference inputs are connected at input modules. The following information is provided to assist in developing a plan:

- Do not route reference input cables near inductive devices (large motors, generators, transformers, etc.) or other equipment which radiates strong magnetic fields.
- If the cable shield is to be connected to the DCD-521/C Shelf, connect the cable shield first.
- Route the reference input cables in paths as diverse as possible. Do not install any type of redundant lead lying parallel and adjacent in the same cable rack.
- Assign redundant timing input cables to different clock input cards.
- Route all reference input cables directly. Do not use tie cables or otherwise break the shield between the DCD-521/C System and the device delivering the clock input. If broken, the shield leads must be bonded.
- Keep all reference input cables unbroken. Do not use tie cables or otherwise break the shield between the DCD-521/C System and the device de-

livering the clock input. If broken, the shield leads must be bonded.

- It is preferable to ground the shield at the timing source end only, but certain vendor applications may require grounding at the receive end. However, under no circumstances should the shield be connected to frame ground at both ends unless one end is capacitor-coupled to ground.

Reference Input Signal Connections

3.12 Installation procedures for all CEP interface module types are the same. Connect the reference inputs to the interface modules (Figures 11 and 12) on the interface panel as follows:

Note: Ensure the ground source is properly installed.

Note: The cables for reference input connections are user-supplied 25.3 mils, 0.643 mm (22 AWG), tinned solid copper, shielded twisted pair cable for E1 and CC, and coaxial cable for analog inputs.

1. Connect one end of the appropriate cable to the interface module connectors. Refer to Figure 11 for connector assignments for the input reference modules with wire-wrap connectors. Refer to Figure 12 for connector assignments for the input reference modules with coaxial connectors.
2. Thread the other end of the cable to the right or left, for connection to customer equipment according to local company Installation Job Specification.

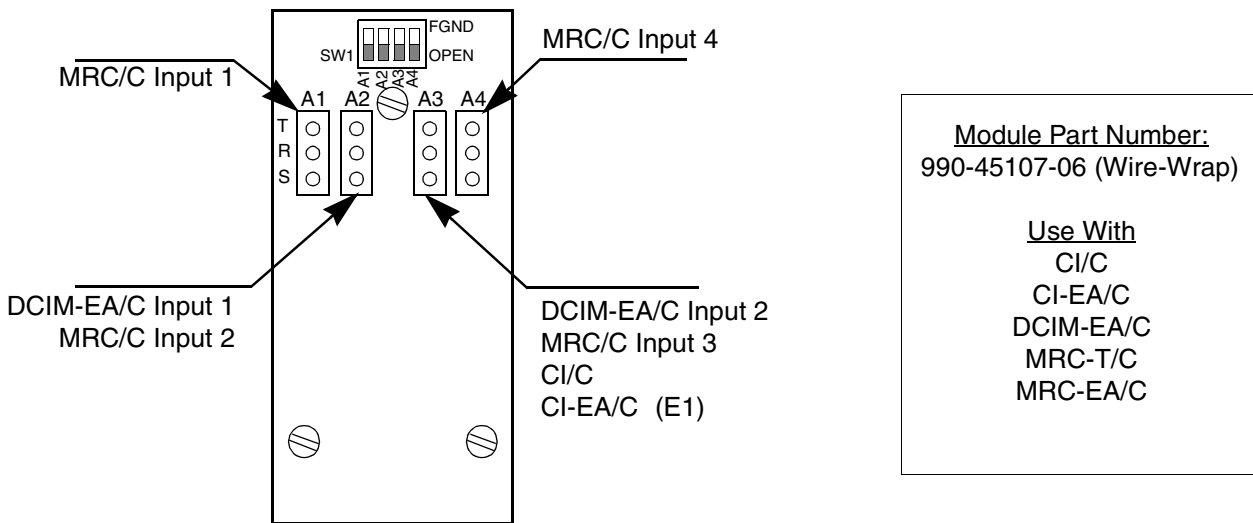
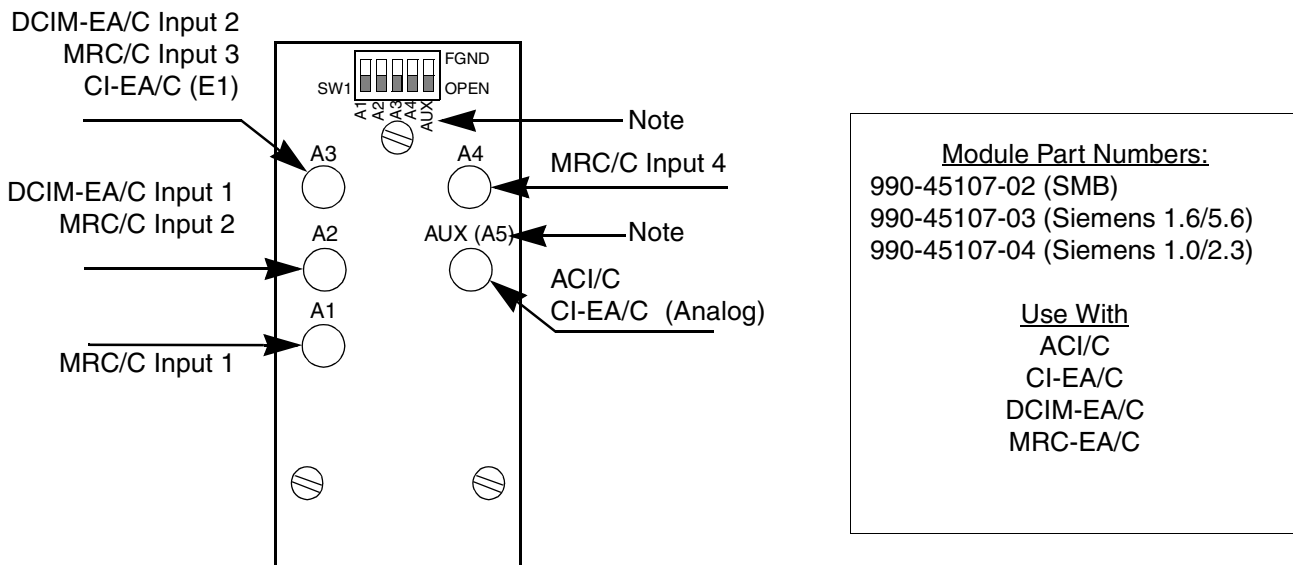

Figure 11. Wire-Wrap Reference Input Module



Note: "AUX" is replaced by "A5" on 990-45107-04 modules.

Figure 12. Coaxial Reference Input Module

E. DCD-LPR/C Connections

3.13 Two BNC connectors on the CEP (Figure 5), J12 (OSC A OUT) and J13 (OSC B OUT), are for connecting to the DCD-LPR/C Shelf. They provide the necessary 5 MHz stratum signal source for the DCD-LPR/C.

3.14 Reference input connections from the DCD-LPR/C connect to the DCD-521/C as any other reference input. Figure 13 shows connections between the DCD-LPR/C and the DCD-521/C.

F. Communication Port Connections

3.15 The MIS/C card sends serial alarm and status data and accepts control commands in TL1 message format via the RS-232 DB9 connectors (COMM1, COMM2, and COMM3) on the CEP.

3.16 The COMM2 connector is for connection to a centralized alarm surveillance and control center, and is switch-configured (on the MIS/C card) for 1200 or 9600 baud and parity. The COMM1 and COMM3 connectors on the CEP are software-configured for 1200 or 9600 baud and parity. All communication ports are set for 8 data bits and 1 stop bit.

3.17 The local company Installation Job Specifications should specify providing a modem circuit, packet switch circuit, or a dedicated private line circuit from the centralized alarm surveillance and control center for connection to the desired COMM port connector when an MIS/C card is provided.

3.18 Use RS-232 cable (user-supplied) with a male DB9 connector to connect from the CEP (refer to Table F and Figure 14 for the DB9 connector pin assignments) to the communication circuit.

Table F. DB9 COMM Connector Pin Assignments

PIN	FUNCTION
1	(No connection)
2	Rx (receive data) (to shelf)
3	Tx (transmit data) (from shelf)
4	DTR (data terminal ready)
5	GND (ground)
6	DSR (data set ready)
7	RTS (request to send)
8	CTS (clear to send)
9	(No connection)

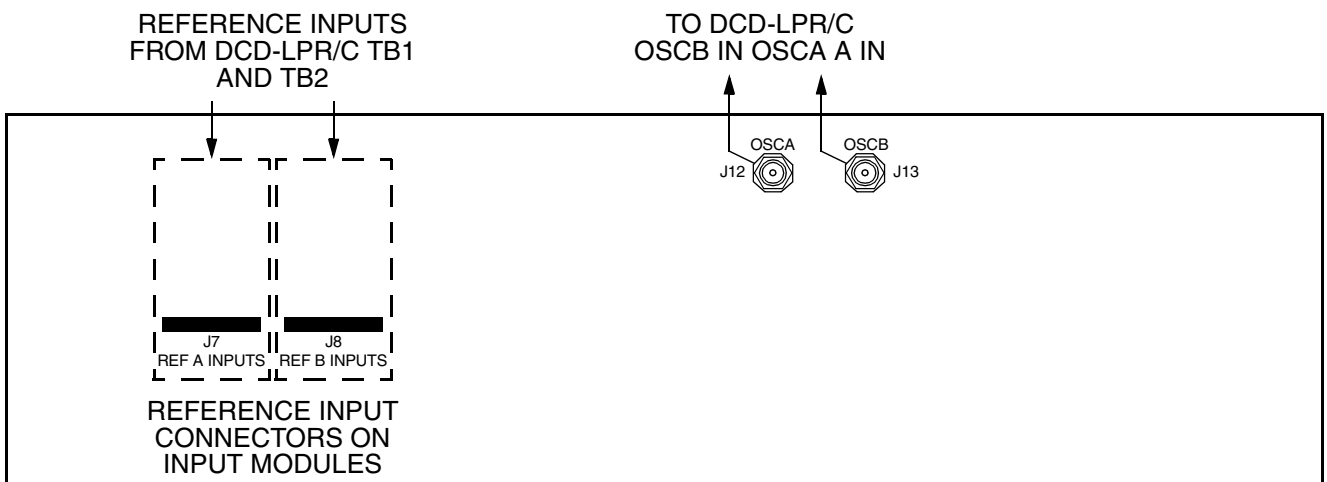

Figure 13. DCD-LPR/C Connections to DCD-521/C CEP

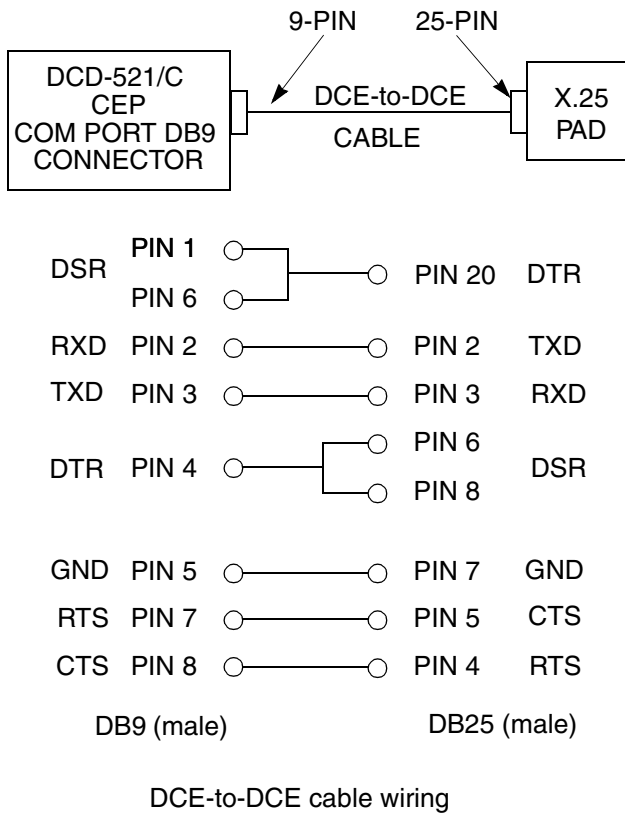

Figure 14. Data Communications Connection

4. TEST AND ACCEPTANCE

4.01 Refer to the Test and Acceptance section of this manual for instructions for testing the DCD-521/C System.

4.02 After the test and acceptance procedures have been completed (as instructed), proceed to the next section.

Caution: Ensure that the procedures referenced in the Test and Acceptance section of this manual have been completed before making the connections in the remainder of this section. Failure to observe this caution may result in a service interruption if the alarm or timing outputs have to be removed to complete the installation.

5. POST-TEST CONNECTIONS

A. MIS/C^{V5} Card in Remote System

5.01 Connect the RS-232 cable between COM3 on each master shelf and expansion shelves.

B. Alarm, Status, and Control Terminations

5.02 The DCD-521/C Shelf has two 50-pin connectors for Office Alarms and Shelf Status indications, Clock Status (A and B) indications, and Control functions. The ALARM/STATUS (J5) connector (Table G) supplies all connections. The ALARM (J6) connector (Table H) supplies only Office Alarm connections.

5.03 The Office Alarm, Shelf Status, and Clock Status pins are loop closure alarms for the central office (CO) audible and visible alarm system. The loop closure pins also provide a telemetry interface to transport remote alarms via remote telemetry equipment scan-point inputs to a centralized alarm surveillance and control center.

5.04 Some loop closures carried by the ALARMS/STATUS (J5) connector are made by relay contacts and others are made by the open collector of a transistor, depending on whether an MIS/C card or an SAI/C card is installed. All open collector closures are connected to the -48 V office battery. No relay contact closure is connected to any voltage.

5.05 All loop closures carried by the ALARMS (J6) connector are made by relay contacts.

5.06 All SAI/C card loop closures, except the HLD OVER A and B closures, are made by relay contact. Figure 15, Figure 16, and Figure 17 show circuit schematics for connecting the alarm, status, and control connector closures to remote scanning telemetry equipment.

5.07 The Control terminals connect to remote telemetry equipment control-point outputs for controlling the alarm cutoff (ACO) on the DCD-521/C Shelf to silence the CO audible alarm.

Table G. 50-pin J5 ALARM/STATUS Pin Assignments

PIN	SIGNAL	FUNCTION GROUP	MIS/C CARD		SAI/C CARD	
			CLOSURE (NOTE 2)	CIRCUIT (NOTE 3)	CLOSURE (NOTE 2)	CIRCUIT (NOTE 3)
1	DIG GND	NA	NA	NA	NA	NA
2	LOCK B (Note 1)	Clock Status	Open collector	Figure 17	Relay contact	Figure 16
3	HLD OVER B (Note 1)	Clock Status	Open collector	Figure 17	Open collector	Figure 17
4	FREE RUN B (Note 1)	Clock Status	Open collector	Figure 17	Relay contact	Figure 16
5	INP UNLCK B (Note 1)	Clock Status	Open collector	Figure 17	Relay contact	Figure 16
6	INP TOL B (Note 1)	Clock Status	Open collector	Figure 17	Relay contact	Figure 16
7	ACO	Control	NA	NA	NA	NA
8	PORT A	Shelf Status	Relay contact	Figure 16	Relay contact	Figure 16
9	CLKL	Shelf Status	Relay contact	Figure 16	Relay contact	Figure 16
10	CRT SI	Shelf Status	Relay contact	Figure 15	Relay contact	Figure 15
11	MIN SI	Shelf Status	Relay contact	Figure 15	Relay contact	Figure 15
12	MAJ SI	Shelf Status	Relay contact	Figure 15	Relay contact	Figure 15
13	BATT ALM	Shelf Status	Open collector	Figure 17	Relay contact	Figure 16
14	CRT AUD C	Office Alarm	Relay contact	Figure 15	Relay contact	Figure 15
15	CRT VIS NO	Office Alarm	Relay contact	Figure 15	Relay contact	Figure 15
16	CRT VIS NC	Office Alarm	Relay contact	Figure 15	Relay contact	Figure 15
17	MAJ AUD C	Office Alarm	Relay contact	Figure 15	Relay contact	Figure 15
18	MAJ VIS NO	Office Alarm	Relay contact	Figure 15	Relay contact	Figure 15
19	MAJ VIS NC	Office Alarm	Relay contact	Figure 15	Relay contact	Figure 15
20	MIN AUD C	Office Alarm	Relay contact	Figure 15	Relay contact	Figure 15
21	MIN VIS NO	Office Alarm	Relay contact	Figure 15	Relay contact	Figure 15
22	MIN VIS NC	Office Alarm	Relay contact	Figure 15	Relay contact	Figure 15
23	FRM GND	NA	NA	NA	NA	NA
24	FRM GND	NA	NA	NA	NA	NA
25	FRM GND	NA	NA	NA	NA	NA
26	FRM GND	NA	NA	NA	NA	NA
27	LOCK A (Note 1)	Clock Status	Open collector	Figure 17	Relay contact	Figure 16
28	HLD OVER A (Note 1)	Clock Status	Open collector	Figure 17	Open collector	Figure 17

Table G. 50-pin J5 ALARM/STATUS Pin Assignments (Contd)

PIN	SIGNAL	FUNCTION GROUP	MIS/C CARD		SAI/C CARD	
			CLOSURE (NOTE 2)	CIRCUIT (NOTE 3)	CLOSURE (NOTE 2)	CIRCUIT (NOTE 3)
29	FREE RUN A (Note 1)	Clock Status	Open collector	Figure 17	Relay contact	Figure 16
30	INP UNLCK A (Note 1)	Clock Status	Open collector	Figure 17	Relay contact	Figure 16
31	INP TOL A (Note 1)	Clock Status	Open collector	Figure 17	Relay contact	Figure 16
32	ACO RTN	Control	NA	NA	NA	NA
33	PORT A RTN	Shelf Status	Relay contact	Figure 16	Relay contact	Figure 16
34	CLKL RTN	Shelf Status	Relay contact	Figure 16	Relay contact	Figure 16
35	CRT SR	Shelf Status	Relay contact	Figure 15	Relay contact	Figure 15
36	MIN SR	Shelf Status	Relay contact	Figure 15	Relay contact	Figure 15
37	MAJ SR	Shelf Status	Relay contact	Figure 15	Relay contact	Figure 15
38	BATT RTN	Shelf Status	Open collector	Figure 15	Relay contact	Figure 16
39	CRT AUD NO	Office Alarm	Relay contact	Figure 15	Relay contact	Figure 15
40	CRT AUD NC	Office Alarm	Relay contact	Figure 15	Relay contact	Figure 15
41	CRT VIS C	Office Alarm	Relay contact	Figure 15	Relay contact	Figure 15
42	MAJ AUD NO	Office Alarm	Relay contact	Figure 15	Relay contact	Figure 15
43	MAJ AUD NC	Office Alarm	Relay contact	Figure 15	Relay contact	Figure 15
44	MAJ VIS C	Office Alarm	Relay contact	Figure 15	Relay contact	Figure 15
45	MIN AUD NO	Office Alarm	Relay contact	Figure 15	Relay contact	Figure 15
46	MIN AUD NC	Office Alarm	Relay contact	Figure 15	Relay contact	Figure 15
47	MIN VIS C	Office Alarm	Relay contact	Figure 15	Relay contact	Figure 15
48	FRM GND	NA	NA	NA	NA	NA
49	FRM GND	NA	NA	NA	NA	NA
50	FRM GND	NA	NA	NA	NA	NA

Notes:

1. There are no designated RTNs for the LOCK, HLD OVER, FREE RUN, INP UNLCK, and INP TOL pins; if a RTN pin is needed for testing purposes, use BATT RTN (pin 38).
2. All open collector closures are connected to the -48 V office battery. No relay contact closure is connected to any voltage.
3. See the figure listed in the CIRCUIT columns for a schematic of the alarm circuit.

Table H. 50-pin J6 ALARM Pin Assignments

PIN	SIGNAL
14	CRT AUD C
15	CRT VIS NO
16	CRT VIS NC
17	MAJ AUD C
18	MAJ VIS NO
19	MAJ VIS NC
20	MIN AUD C
21	MIN VIS NO
22	MIN VIS NC
23	FRM GND
24	FRM GND
25	FRM GND
39	CRT AUD NO

Table H. 50-pin J6 ALARM Pin Assignments (Contd)

PIN	SIGNAL
40	CRT AUD NC
41	CRT VIS C
42	MAJ AUD NO
43	MAJ AUD NC
44	MAJ VIS C
45	MIN AUD NO
46	MIN AUD NC
47	MIN VIS C
48	FRM GND
49	FRM GND
50	FRM GND
Note: Pins not listed are not connected.	

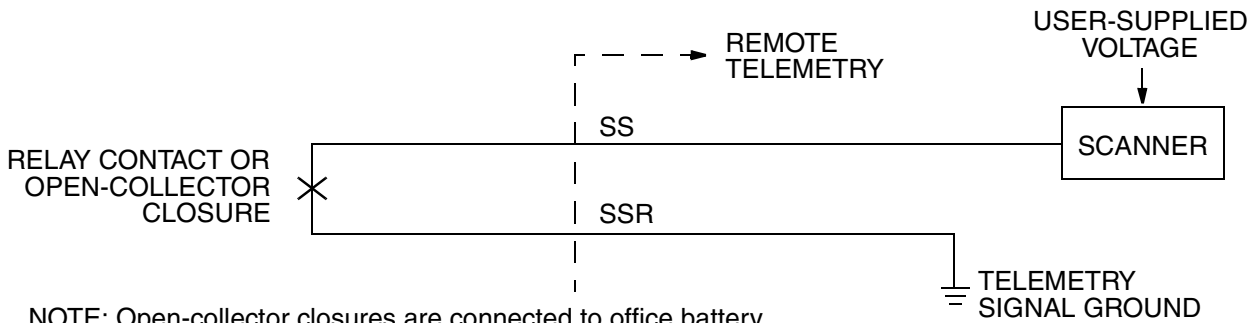

NOTE: Open-collector closures are connected to office battery voltage of -48 V. Relay contact closures are not connected to any voltage.

Figure 15. Isolated Loop Closure Inside Building (SS Type 1)

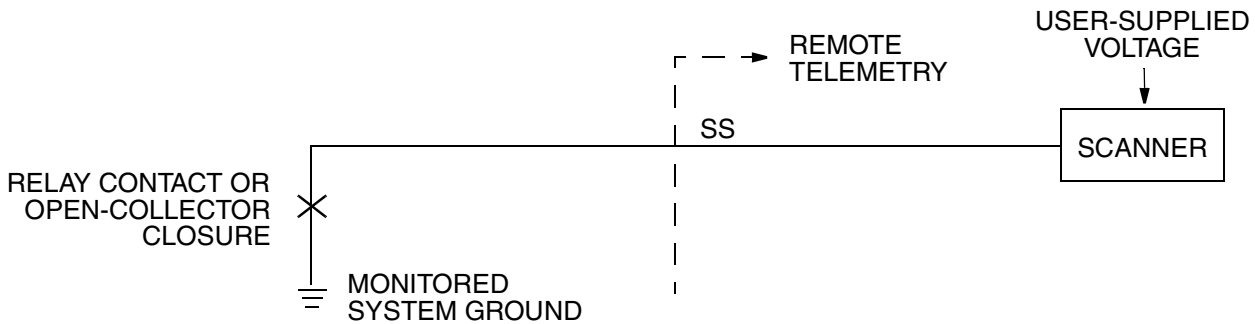

NOTE: Open-collector closures are connected to office battery voltage of -48 V. Relay contact closures are not connected to any voltage.

Figure 16. Isolated Closure to Ground (SS Type 2)

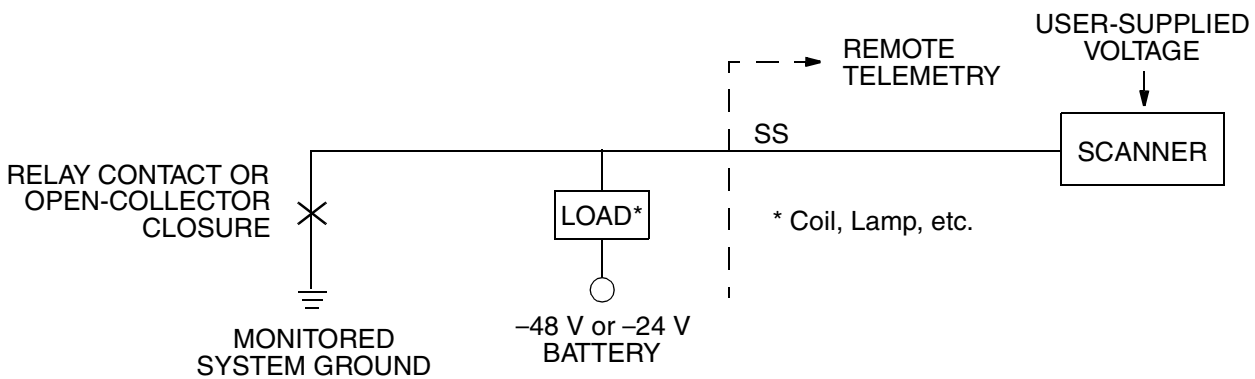

NOTE: Open-collector closures are connected to office battery voltage of -48 V. Relay contact closures are not connected to any voltage.

Figure 17. Closure to Ground with Load (SS Type 3)

5.08 Either the ALARMS (J6) connector or the ALARMS/STATUS (J5) connector on the master shelf CEP may be connected to the CO alarm system. In a multishelf system, the Shelf Status, Clock Status, and Control signals are carried between the shelves by the intrashelf communication cables. Only the Office Alarms need to be connected between the shelves.

Office Alarm Connections

5.09 The Office Alarms are carried on both the ALARMS/STATUS (J6) connector (Table G) and ALARMS (J5) connector (Table H). These alarms provide audible and visible alarms in critical, major, and minor levels of severity. All alarms in this group are relay contact closures for connection to the CO audible/visible alarm system. Both normally open (NO) and normally closed (NC) contacts referenced to a common (C) contact are available, as required by the CO alarm system.

5.10 If the CO alarm system recognizes only two levels of alarms, major and minor, strap the shelf CRITICAL terminals to the shelf MAJOR terminals before connecting to the CO alarm system.

5.11 Either the ALARMS (J6) connector or the ALARMS/STATUS (J5) connector on the master shelf CEP may be connected to the CO alarms system. Only the Office Alarms need to be connected between the shelves in a multishelf system.

Shelf Status and Clock Status (A and B) Connections

5.12 The Shelf Status and Clock Status closures are carried on the ALARMS/STATUS (J6) connector (Table G). These closures provide for connection to remote telemetry equipment for transport to a centralized alarm surveillance and control center. These loop closures provide indications of the type of conditions and the severity associated with the alarms. Both normally open (NO) and normally closed (NC) contacts referenced to a common (C) contact are available, as required by the CO alarm system.

Note: CLKL RTN (clock loss return), PRT A RTN (port alarm return) and BATT RTN (battery alarm return) are internally connected to battery return (TB1 and TB2 RTN terminals). HLD OVER A and B terminals have -48 V dc through relay windings.

5.13 The CRITICAL, MAJOR, MINOR, and BATT ALM terminals are relay contact closures. All other Shelf Status and Clock Status terminals are open collector type (PNP open collector, -60 V, 500 mA maximum). Open collector terminals are designated SI for the status indicator terminals and SR for the status return terminals.

Control Connection

5.14 The CONTROL function remotely operates the ACO function on the SAI/C or MIS/C card.

Caution: Do not connect CONTROL function terminals to E2A equipment scan points. This causes erroneous alarms on the E2A and the CONTROL functions do not operate.

Connecting the Alarms

5.15 The alarm relays in the shelf are in an operated (latched) state when power is applied to the shelf. In an alarm condition or loss of dc power to the shelf, the normally open contacts close between the NO and C terminals, and the normally closed contacts open between the NC and C terminals.

5.16 Some alarm and SI closures are “dry” (-48 V dc not applied to terminal) and others are “wet” (-48 V dc applied to terminal), depending on whether the SAI/C or MIS/C card is installed.

5.17 The NO terminals may be connected between shelves in a multishelf system as a daisy-chain. Use a customer-supplied 50-pin cable with straight-through connections (i.e., pin 1 on one connector must be connected to pin 1 on the other connector, pin 2 to pin 2, etcetera). If the C terminal is used as a common between critical, major, and minor alarms in a daisy-chain of NO alarms, observe tip-ring (T-R) polarity at the CO alarm system.

5.18 The NC terminals must be connected in series, and not connected as a daisy chain. A special cable must be constructed and supplied by the customer. Figure 18 is a generalized schematic showing typical series connections.

5.19 Figure 19 shows the connectors used in a standard multishelf system configuration.

5.20 If the alarm cable is shielded, connect the shield to ground at only one end of the cable. If con-

necting the shield to ground at the DCD-521/C System, use the TB5 terminal on the CEP (Figure 5).

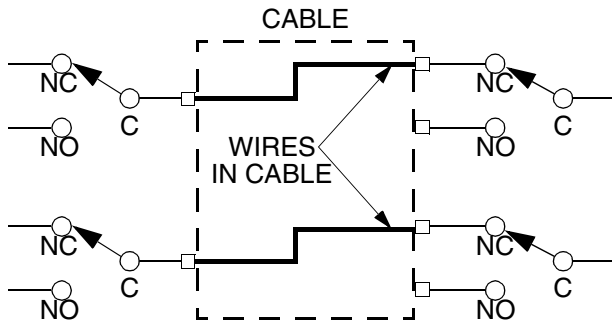

Figure 18. Series Connections for NC Alarms Cable

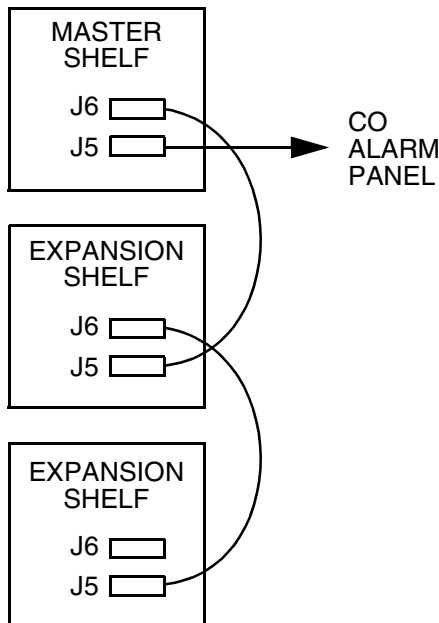

Figure 19. Alarm Cable Connections

5.21 Perform the following to connect the master shelf alarms to the CO audible/visible alarm system:

1. Use a cable with a 50-pin cinch connector to mate with the DCD-521/C alarms connector and 50 solid copper wires. Each wire in the cable must have a diameter of 20.1 mils, 0.511 mm (24 AWG). Prepare the office alarms end of the cable for connection to the CO alarms system using local company practice.

2. Connect the master shelf alarms to the CO alarm system per the local company Installation Job Specifications.
3. If connecting the shield to ground at the DCD-521/C System, use the TB5 terminal on the CEP (Figure 5).

5.22 When using the NO alarm closures, perform the following to connect the expansion shelf alarms to the master shelf:

1. Use a cable with 50 solid copper wires (20.1 mils, 0.511 mm [24 AWG]) and a 50-pin cinch connector on each end to mate with the DCD-521/C alarms connectors.
2. Connect the wires in the cable to make “straight-through” connections between the pins of the connectors (pin 1 must be connected to pin 1, pin 2 to pin 2, etc.).
3. Connect the cable from the ALARMS/STATUS (J5) connector of one expansion shelf to the ALARMS (J6) connector of the next expansion shelf. Repeat until all expansion shelves are connected.
4. Connect the cable from the ALARMS (J6) connector of one expansion shelf to the ALARMS/STATUS (J5) connector of the master shelf.
5. If connecting the shield to ground at the DCD-521/C System, use the TB5 terminal on the CEP (Figure 5).
6. After alarm wiring is complete, test the alarms per the local company Installation Job Specifications. One way to verify the cabling is to put a short across each NO and C terminal pair and verify that the appropriate audible alarm sounds, visible alarm lights, and message is generated on the host computer (if provisioned). Each scan-point in the operations system (OS) computer should be programmed with a message that identifies the alarm or status state. Since the available field length may vary between different OS computers, Table I contains suggested OS messages.

Table I. OS Alarm and Status Messages (Suggested)

ALARM/STATUS TERMINAL	OS MESSAGE
SHELF STATUS	
CRT	CRITICAL - All Sync Output Failed
MAJ	MAJOR - Sync Potentially Service Affecting
MIN	MINOR - Sync Non-service Affecting
PRT A	Sync - Timing Output Port Failed
CLKL	Sync - Input Reference Failed
BATT ALM	Sync - Blown Fuse A or B/Loss BATT A or B
CLOCK STATUS A	
LOCK	Sync - Clock A Lost Lock With Reference
HLD OVER	Sync - Clock A in Holdover Mode
FREE RUN	Sync - Clock A in Freerun Mode
INP UNLCK	Sync - Input Ref A to Ref B has Freq Offset
INP TOL	Sync - Input Ref A to Clk A has Freq Offset
CLOCK STATUS B	
LOCK	Sync - Clock B Lost Lock With Reference
HLD OVER	Sync - Clock B in Holdover Mode
FREE RUN	Sync - Clock B in Freerun Mode
INP UNLCK	Sync - Input Ref A to Ref B has Freq Offset
INP TOL	Sync - Input Ref B to Clk B has Freq Offset

5.23 When using the NC alarm closures, use a cable prepared to connect alarms in series (Figure 18), and perform steps 1, 3, 4, and 5 of the procedure when using NO alarm closures.

C. Timing Output Connections

5.24 This section provides guidelines and instructions for connecting network elements (NE) to the timing output modules for the output cards listed in Table J. The local company Installation Job Specifications should specify which DCD-521/C timing output port is to be cabled to which network elements, what type of cable and connectors to use, and the routing of the cables between the DCD-521/C interface panel and the network elements. Consult the network element manufacturer’s documentation for proper connection, termination, and cutover procedures at the network element.

Table J. Timing Output Card Connections

CARD	CARD CONNECTIONS FIGURE
EA10/C EA10M/C	20, 21, 22, 24, 25, 26
TOAA/C	29
TOCA/C	20, 26
TO-EA/C	21, 22, 23, 24, 26
TO-EA5/C	20, 21, 22, 23, 24, 25, 26
TOEA/C	23, 24, 26
TOGA/C	23, 24, 25
TOLA/C	27, 28
TOTA/C	20, 26
TOTA-5/C	20
TOTL/C	20

Initial Considerations

5.25 All timing output connections on the DCD Shelf are made at an interface module on the inter-

face panel. If the local company Installation Job Specifications do not specify the DCD Shelf timing output assignments, a local assignment plan must be developed before proceeding with the connections. The following information is provided to assist in developing the local output assignment plan.

5.26 Consult the network element (NE) manufacturer's equipment manuals to determine the external timing signal type required by the NE, the type of cable needed to make the connection, and the type of connectors required for the NE end of the cable. The following is a list of NE types and the TO cards that are often used to time them.

- Digital Loop Carrier (DLC) systems, e.g., NTI DMS-1 Urban and AT&T SLC Series 5, require 2 TOCA ports per system.
- SDH terminals require 2 TOGA, 2 TOEA, or 2 TO-EA ports per terminal. Two ports per terminal are recommended for diversity.
- Digital Loop Carrier (DLC) systems, e.g., NTI DMS-1 Urban and AT&T SLC Series 5 require 2 TOCA ports per system.
- Some digital switch machines require 2 or 4 TOEA or 2 or 4 TO-EA ports per machine.
- If an NE requires analog sine wave signals, use 1 or 2 TOAA ports per NE.
- SONET OC-n terminals require 2 TOTA ports per terminal or per six terminals (vendor specific). Two ports per terminal are recommended for diversity.
- Some digital switch machines and subscriber premise NEs require RS-422 or RS-423 square wave signals, and generally require 2 TOLA ports per switch or NE.

5.27 For NEs that require primary and secondary timing references, assign output ports from two separate TO cards of the same type for diversity. For example, assign the primary reference to port 1 on the EA10/C card in slot TO1, and the secondary reference to port 1 on the EA10/C card in slot TO2.

Connections

5.28 Refer to Figures 20 through 29 and the following to connect to a timing output module.

1. Ensure the front panels are removed from the DCD-521/C System.
2. Guide the output cable ends into the cable duct from either (or both) side(s) of the equipment rack.
3. Connect the cables to the interface module of the appropriate output card on the interface panel. Tag the cables for identification.

4. Connect the timing output signal cables to the equipment being timed by the DCD-521/C.

Note: If connecting to a wire-wrap output module, follow local company practice, and using 25.3 mils, 0.643 mm or 20.1 mils, 0.511 mm (22 AWG or 24 AWG) tinned solid copper, shielded twisted pair cable, prepare cable ends for wire-wrapping. Ensure that no bare wire ends are exposed, and no wires are nicked.

5. Replace the front panel.

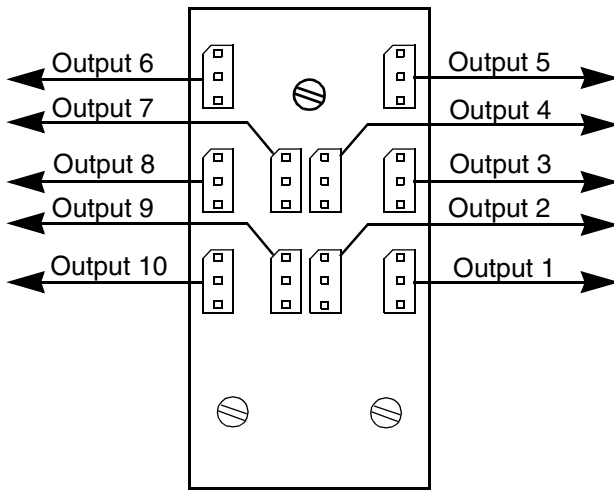

Use With
EA10/C
EA10M/C
TO-EA5/C
TOTA/C
TOTA-5/C
TOTL/C

Figure 20. 990-45105-06 Output Module

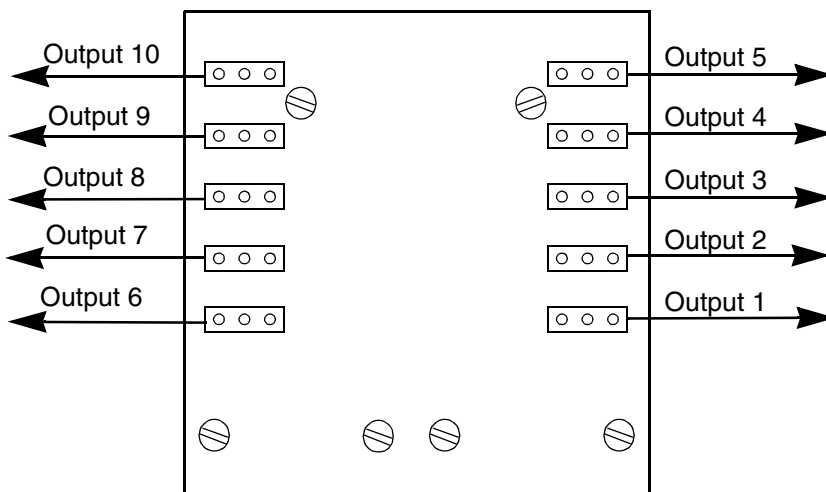

Use With
EA10/C
TO-EA5/C
TO-EA/C
(for redundant pairs)

Figure 21. 990-45105-10 Output Module

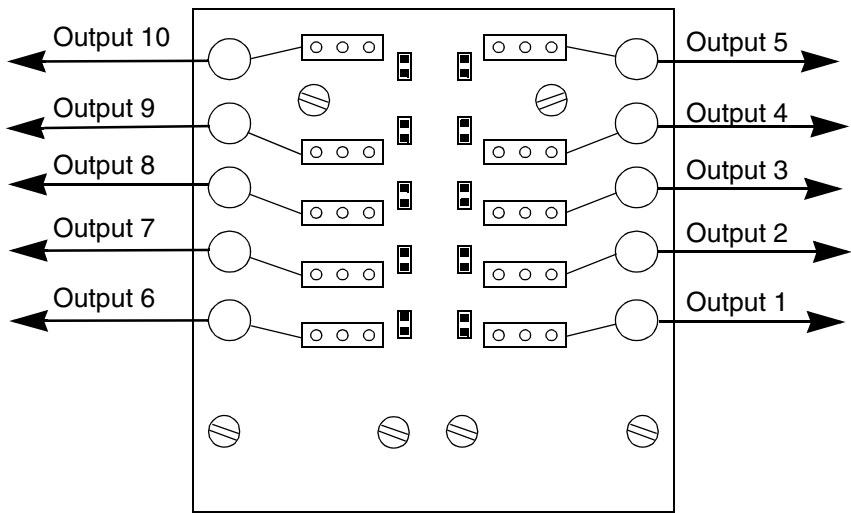

Note: Each output may be wire-wrap (jumper on) or Siemens 1.6/5.6 (jumper off).

Use With
 EA10/C
 EA10M/C
 TO-EA5/C
 TO-EA/C
 (for redundant pairs)

Figure 22. 990-45105-11 Output Module

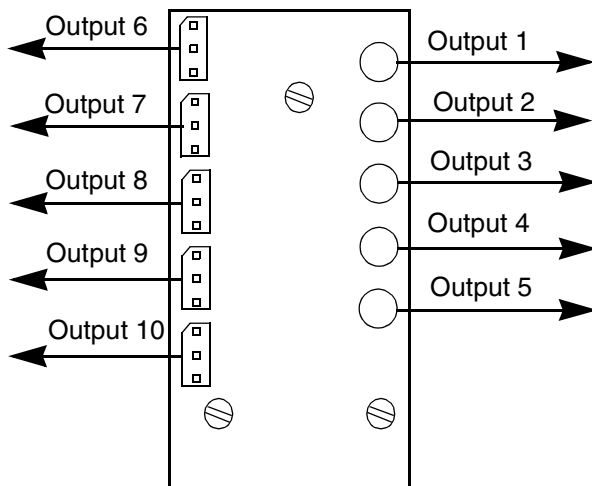

Note: Outputs 1 through 5 are Siemens 1.6/5.6, outputs 6 through 10 are wire-wrap.

Use With
 TO-EA5/C
 TO-EA/C
 TOEA/C
 TOGA/C

Figure 23. 990-45105-12 Output Module

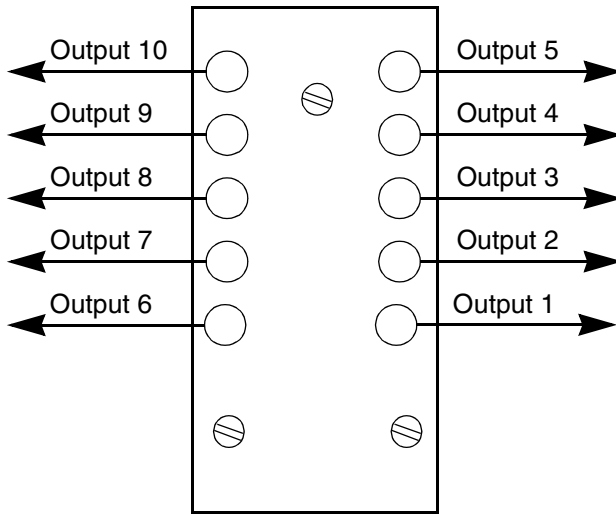

Module Part Numbers
 990-45105-13 (SMB)
 990-45105-14 (Siemens 1.6/5.6)
 990-45105-15 (Siemens 1.0/2.3)

Use With
 EA10/C
 EA10M/C
 TO-EA/C
 TO-EA5/C
 TOEA/C
 TOGA/C

Figure 24. 990-45105-13, -14, -15 Output Module

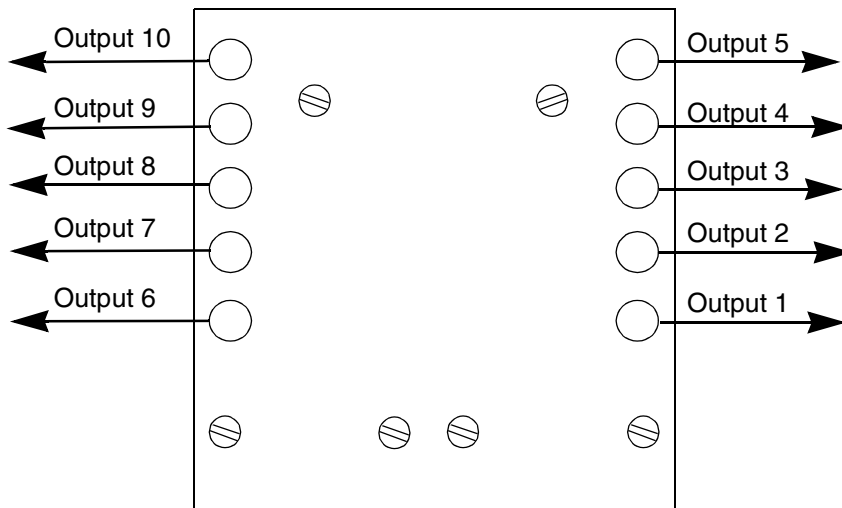

Module Part Numbers
 990-45105-16 (SMB)
 990-45105-17 (Siemens 1.6/5.6)
 990-45105-18 (Siemens 1.0/2.3)

Use With
 EA10/C
 EA10M/C
 TO-EA5/C
 TOGA/C (Note)
 (for redundant pairs)

Note: For TOGA/C card pairs, use module 990-45105-16 only

Figure 25. 990-45105-16, -17, -18 Output Module

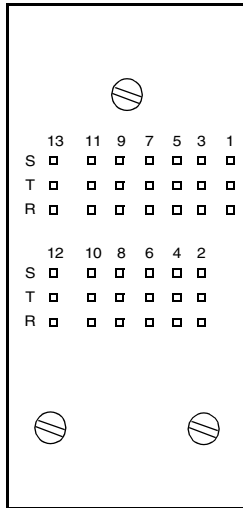

Note: The terminal set number is the timing output card port number.

Use With
 EA10/C
 EA10M/C
 TOCA/C
 TO-EA5/C
 TO-EA/C
 TOEA/C
 TOTA/C

Figure 26. 990-45108-01 Output Module

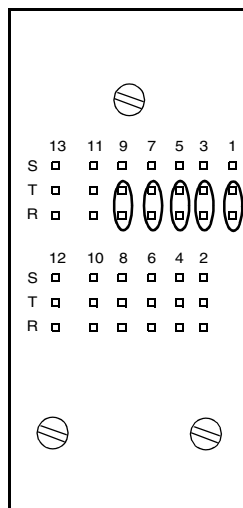

Note: Outputs 1 through 5 are available at the wire wrap terminal sets 1, 3, 5, 7, and 9. The TOLA/C card RS-422 (+) driver connects to T and the RS-422 (-) driver connects to R.

Use With
 TOLA/C (RS-422 signals)
 TOLA/C (097-44023-03 only,
 RS-232 signal) (Note)

Note: For a 097-44023-03 (RS-232) card, the T pin is the clock, and the R pin is the ground. Terminal set 10 is a test port.

Figure 27. 990-45108-01 Output Module for TOLA/C Card with RS-422 and RS-232 Signals

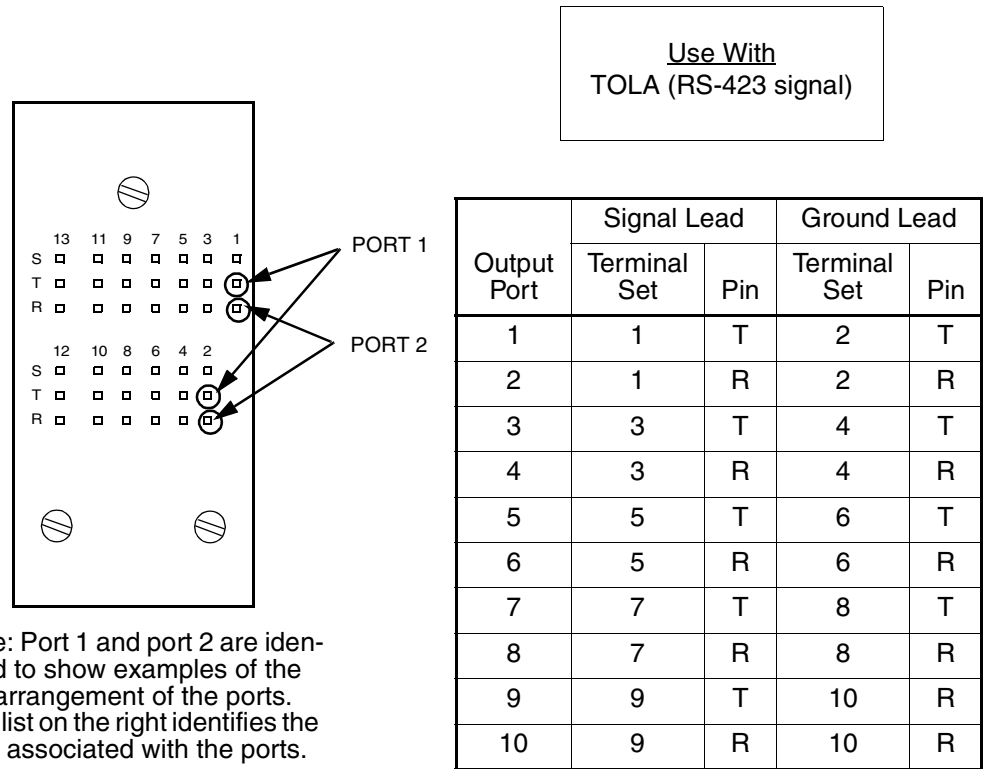

Figure 28. 990-45108-01 Output Module for TOLA/C Card with RS-423 Signals

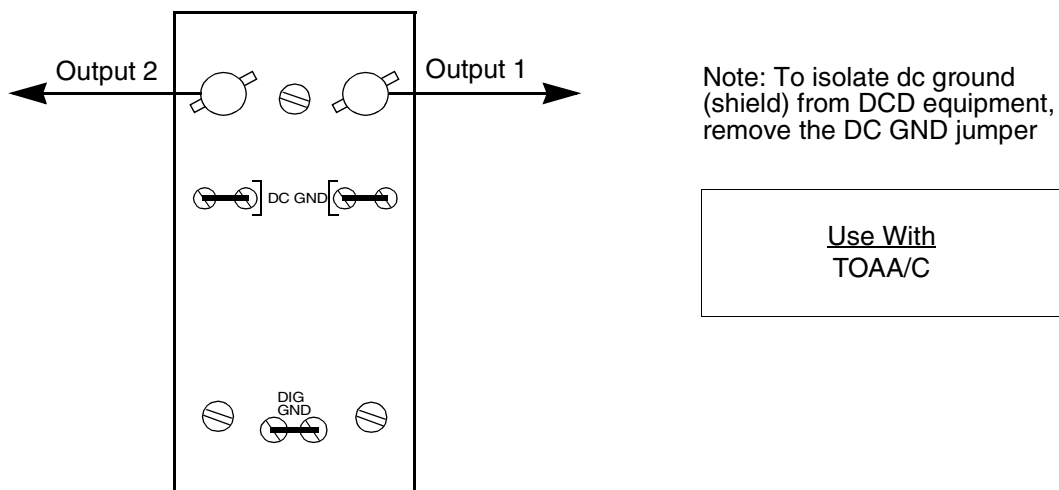

Figure 29. 990-45122-01 Output Module

D. PSM/C Module Connections

5.29 Refer to Figure 30 or Figure 31 and the following to connect to a PSM/C module.

1. Guide the cable ends into the cable duct from either (or both) side(s) of the equipment rack.
2. Route the cables to the appropriate interface module on the CEP or interface panel. Tag the cables for identification.

Note: If connecting to a wire-wrap interface module, follow local company practice, use 25.3 mils, 0.643 mm (22 AWG) or 20.1 mils, 0.511 mm (24 AWG) tinned solid copper, shielded twisted pair cable. Prepare cable ends for wire-wrapping. Ensure that no bare wire ends are exposed, and no wires are nicked.

3. Connect the cables to the PSM/C module.
4. Repeat Steps 1 through 3 for each shelf with PSM/C cards.

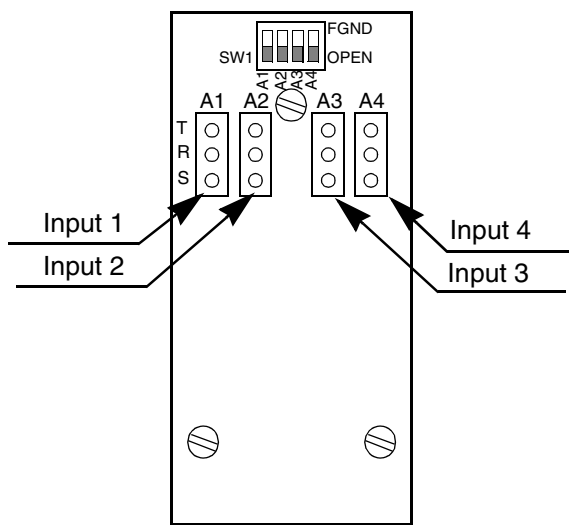

Module Part Number
990-45106-11 (Wire-Wrap)

Use With
PSM-T/C
PSM-E/C
PSM-EA/C

Figure 30. Wire-Wrap PSM/C Input Module

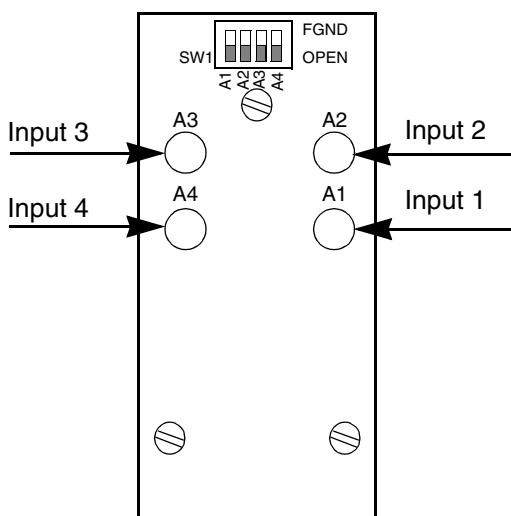

Module Part Numbers
990-45106-12 (Siemens 1.6/5.6)
990-45106-13 (BNC)
990-45106-14 (SMB)
990-45106-15 (Siemens 1.0/2.3)

Use With
PSM-E/C
PSM-EA /C

Figure 31. Coaxial PSM/C Input Module

E. ESCIU/C Connections

5.30 The ESCIU/C cards are different from the output cards. Output cards provide external reference clock signals for network elements. The ESCIU/C card inserts the DCD clock directly into E1 traffic-carrying links.

5.31 The ESCIU/C module is used exclusively with the ESCIU/C card. The ESCIU/C module has a bypass relay which closes contacts to maintain continuity on the traffic spans if the ESCIU/C card fails or is removed from the shelf. Always connect the ESCIU/C card into the traffic-bearing links using an ESCIU/C module.

5.32 The “A” direction (East to West) of transmission inserts the DCD clock signal into the received traffic span’s bitstream. The “B” direction (West to East) is passed through the ESCIU/C without clock insertion.

5.33 The ESCIU/C cards’ A and B direction output signals conform to CCITT G.703 paragraph 6 specifications, and are designed for connection into the E1 bitstream at the digital distribution frame (DDF). The network elements receiving a signal from the ESCIU/C must be able to receive signals that conform to CCITT G.703 paragraph 6 specifications.

5.34 The ESCIU/C module is cabled as shown in Figure 32.

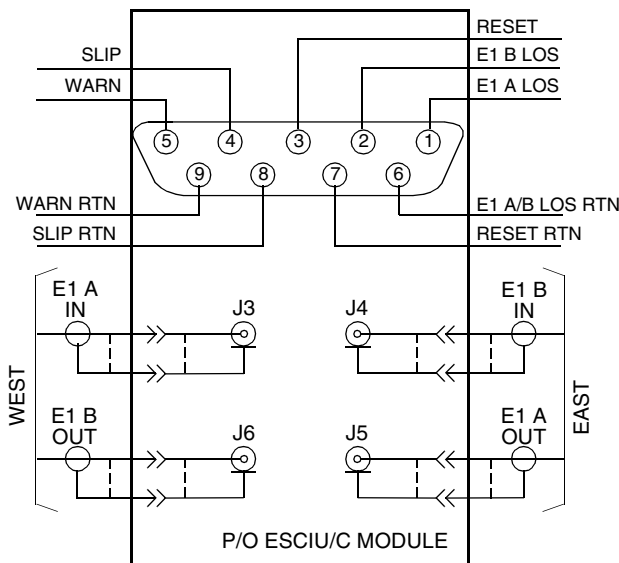

Figure 32. ESCIU/C Module Connections

Connecting at the DDF

5.35 For 75 Ω impedance, use BT 3002 or equivalent cable (user-supplied), to connect the module’s EAST and WEST terminals to the two network elements on the spans; refer to Table K and Figure 32. Repeat for each module installed.

Table K. ESCIU/C Module to Access Jack Connections

MODULE	ACCESS JACK
WEST A IN (J3)	IN Jack #1 (Jack normal side)
WEST B OUT (J6)	OUT Jack #1 (Jack normal side)
EAST B IN (J4)	IN Jack #2 (Jack normal side)
EAST A OUT (J5)	OUT Jack #2 (Jack normal side)
Note: Jack numbers are for reference only.	

Connecting without a DDF

5.36 If a standard level DDF (cross-connect point) is not available, connect the ESCIU/C directly to the line and office network element’s traffic-carrying E1 facility as follows:

5.37 For 75 Ω impedance, use BT 3002 or equivalent cable (user-supplied) to connect the module’s EAST and WEST terminals to the two network elements on the spans; refer to Figure 32 and Table L. Repeat for each module installed.

Table L. ESCIU/C Module to NE Connections

MODULE	NETWORK ELEMENT (NE)
WEST A IN (J3)	Transmit or OUT side of the NE link to be retimed from the DCD
WEST B OUT (J6)	Receive or IN side of the NE connected to WEST A IN
EAST B IN (J4)	Transmit or OUT side of the NE being retimed from the DCD
EAST A OUT (J5)	Receive or IN side of the NE connected to EAST A IN.
Note: Transmit or OUT direction is <u>toward</u> the ESCIU/C module. Receive or IN direction is <u>from</u> the ESCIU/C module.	

Connecting the Alarms

5.38 If the module is to be cabled to alarm monitoring equipment, consult local company Installation Job Specifications.

5.39 Use the appropriate cable to connect from the DB9 connector (J2) on the module to alarm monitoring equipment; refer to Figure 32 and Table M. Repeat for each module installed.

Table M. ESCIU/C Alarm and Control Connections

TERMINAL SETS	COMMENTS
WARN (Alarm)	Do not cable
SLIP (Alarm)	Cable to E2A telemetry equipment scan-point
RESET (Control)	Cable to E2A telemetry equipment control-point
E1 A LOS (Alarm)	Cable to E2A telemetry equipment scan-point
E1 B LOS (Alarm)	Cable to E2A telemetry equipment scan-point

F. ESCIU/C Cutover Procedures

5.40 The ESCIU/C card must be cabled into the bit-stream of a traffic-carrying E1 system. This procedure assumes that the installation cabling was

completed according to instructions in this section, and the test and acceptance was completed per the Test and Acceptance section of this manual.

Out-of-Service Equipment

5.41 If DDF access jack sets *are not* cabled to the ESCIU/C module, the following out-of-service cutover procedure must be used. Consult the local company Installation Job Specifications to ensure that the network element to be retimed from the DCD-521/C Shelf clock is connected to the ESCIU/C module correctly. Refer to Figure 33 for the following procedure:

1. Remove from service (turn down) the traffic trunks on the E1 system to be cutover to the ESCIU/C module.
2. Remove the existing cabling between the line NE and office NE transmit (OUT) and receive (IN) terminals, including:
 - Transmit (OUT) on the line NE terminals to receive (IN) on the office NE terminals
 - Receive (IN) on the line NE terminals to transmit (OUT) on the office NE terminals
3. Connect the new ESCIU/C module cables per the following:
 - WEST IN terminals on the module to transmit (OUT) terminals on the NE not being timed from the DCD-521/C Shelf
 - WEST B OUT terminals on the module to receive (IN) terminals on the NE not being timed from the DCD-521/C Shelf
 - EAST A IN terminals on the module to transmit (OUT) terminals on the NE being timed from the DCD-521/C Shelf
 - EAST B OUT terminals on the module to receive (IN) terminals on the NE being timed from the DCD-521/C Shelf
4. Verify that there are no alarms on the NEs on the E1 system. If there are alarms, recheck the new cabling between the NEs and the ESCIU/C module.
5. Restore (turn up) the traffic trunks to service.

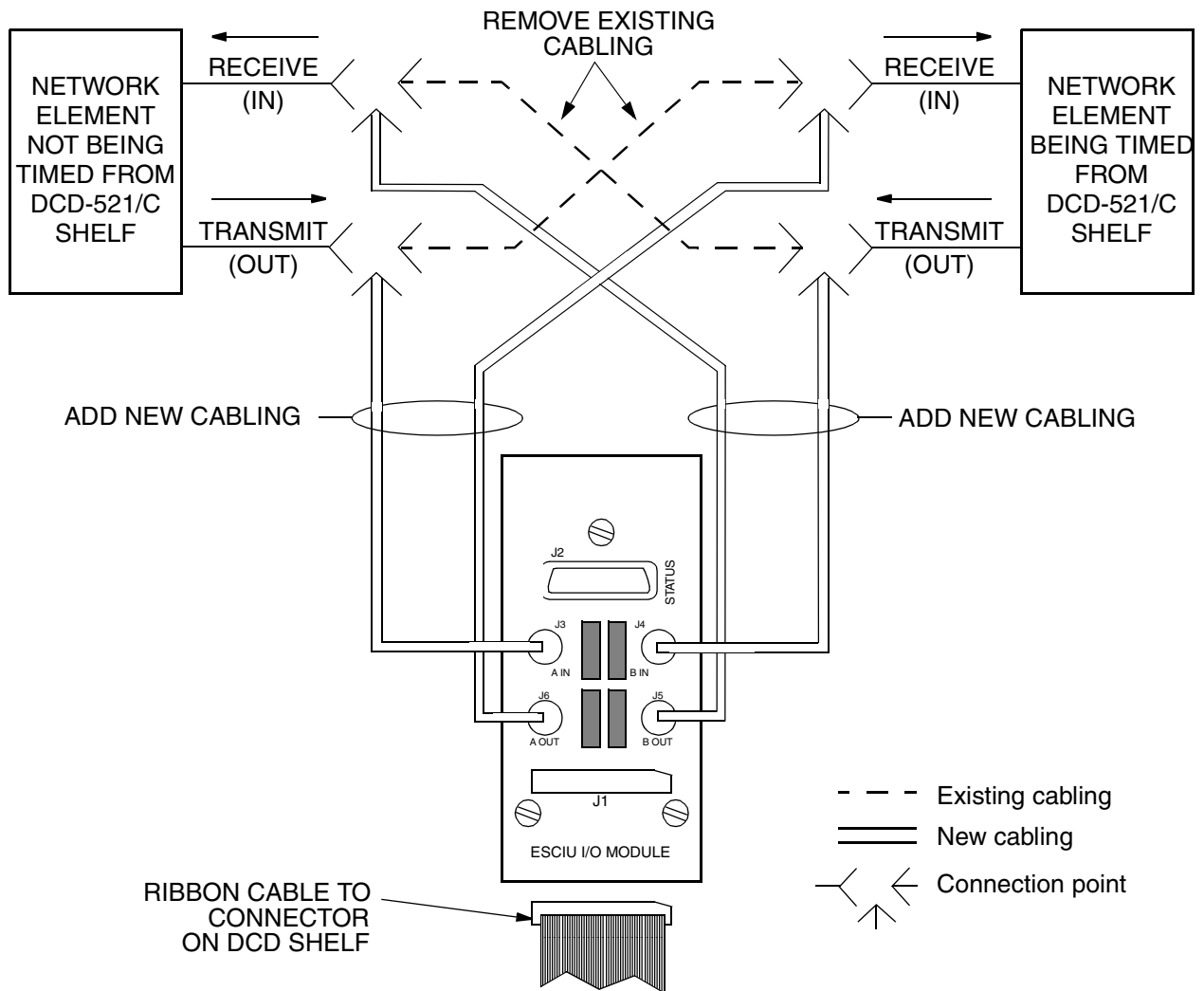

Figure 33. ESCIU Cutover without Jacks (Out-of-Service)

6. Repeat Steps 1 through 5 for each ESCIU/C installed in the DCD-521/C Shelf.

In-Service Equipment

5.42 If standard digital signal level access jack sets, such as DSX-1 jacks, were cabled to the ESCIU/C module, the following in-service cutover procedure must be used. Consult the local company Installation Job Specifications to ensure that the network element to be retimed from the DCD-521/C Shelf clock (BITS) will be connected to the ESCIU/C module WEST A OUT terminals (see Figure 32). Refer to Figure 34 for the following procedure:

1. Patch a bridging repeater from the MON jack of one NE to the IN jack of the other NE in both directions of transmission on the E1 system to be cutover. Place a 75 Ω termination plug in the OUT jack in each direction.
2. Remove the cross-connect wiring from the OUT to IN jacks (off-normal side of jacks) in both directions of transmission.
3. Install new cross-connect wiring from the ESCIU/C jack sets to the NEs as follows:
 - EAST A IN jack on the module to OUT jack on the NE not being timed from the DCD-521/C Shelf
 - EAST B OUT jack on the module to IN jack on the NE not being timed from the DCD-521/C Shelf
 - WEST B IN jack on the module to OUT jack on the NE being timed from the DCD-521/C Shelf
 - WEST A OUT jack on the module to IN jack on the NE being timed from the DCD-521/C Shelf
4. Remove the 75 Ω (E1) termination plug from the OUT jack and patch cords from the NE IN jack. The E1 system bitstream is now going through the ESCIU/C card.
5. Verify that there are no alarms on the NEs on the E1 system. If there are alarms, reinsert patch cords in the IN jack and the termination plugs in the OUT jack. Recheck the cross-connect wiring just installed, and repeat Step 4.
6. Remove the remaining patch cords from the NE MON jack.
7. Repeat Steps 1 through 6 for each ESCIU/C card installed in the DCD-521/C Shelf.

5.43 Consult Symmetricom CTAC for additional information regarding system cutovers.

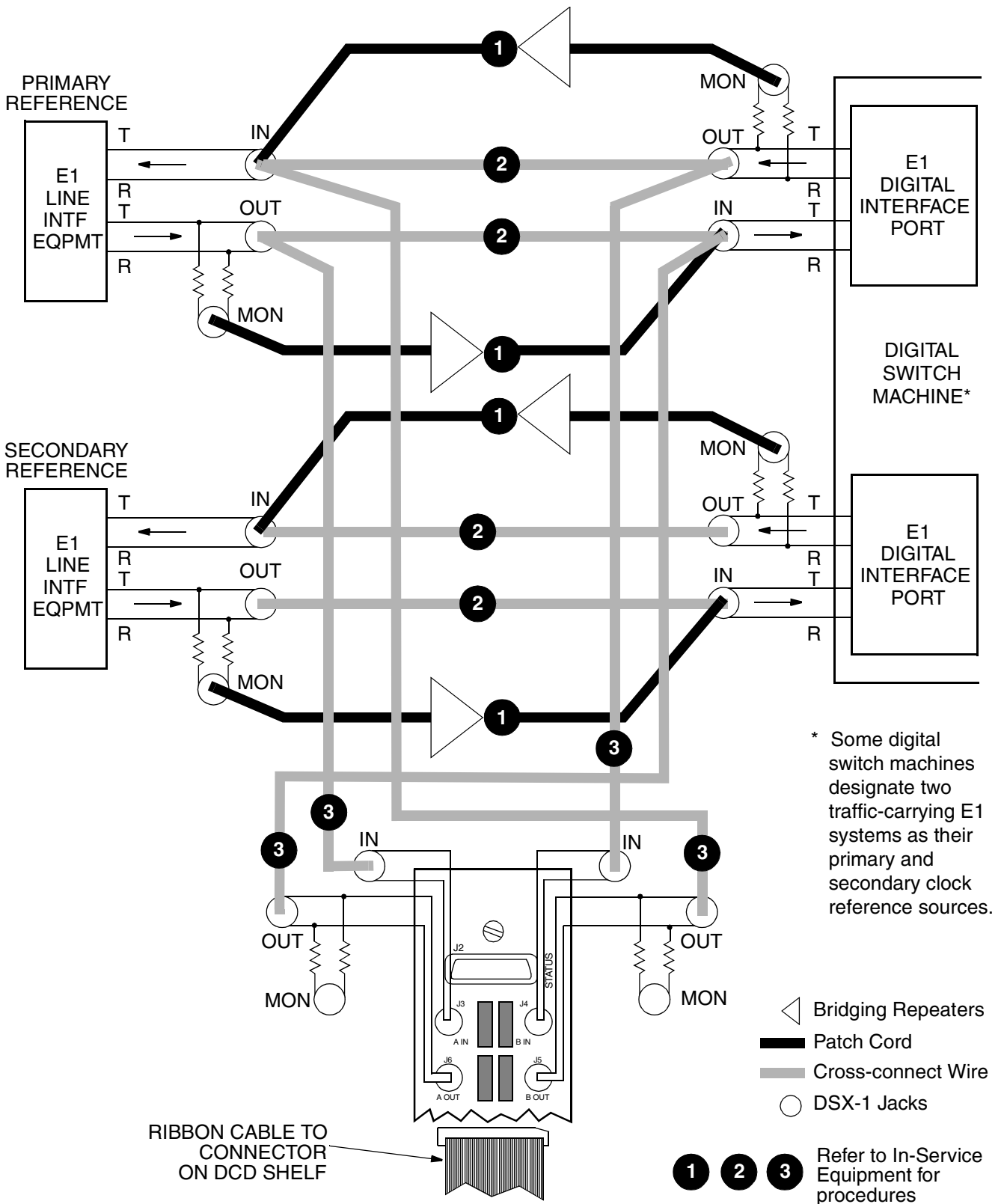

Figure 34. ESCIU Cutover with Jacks (In-Service)